

# ASSEMBLY INSTRUCTIONS

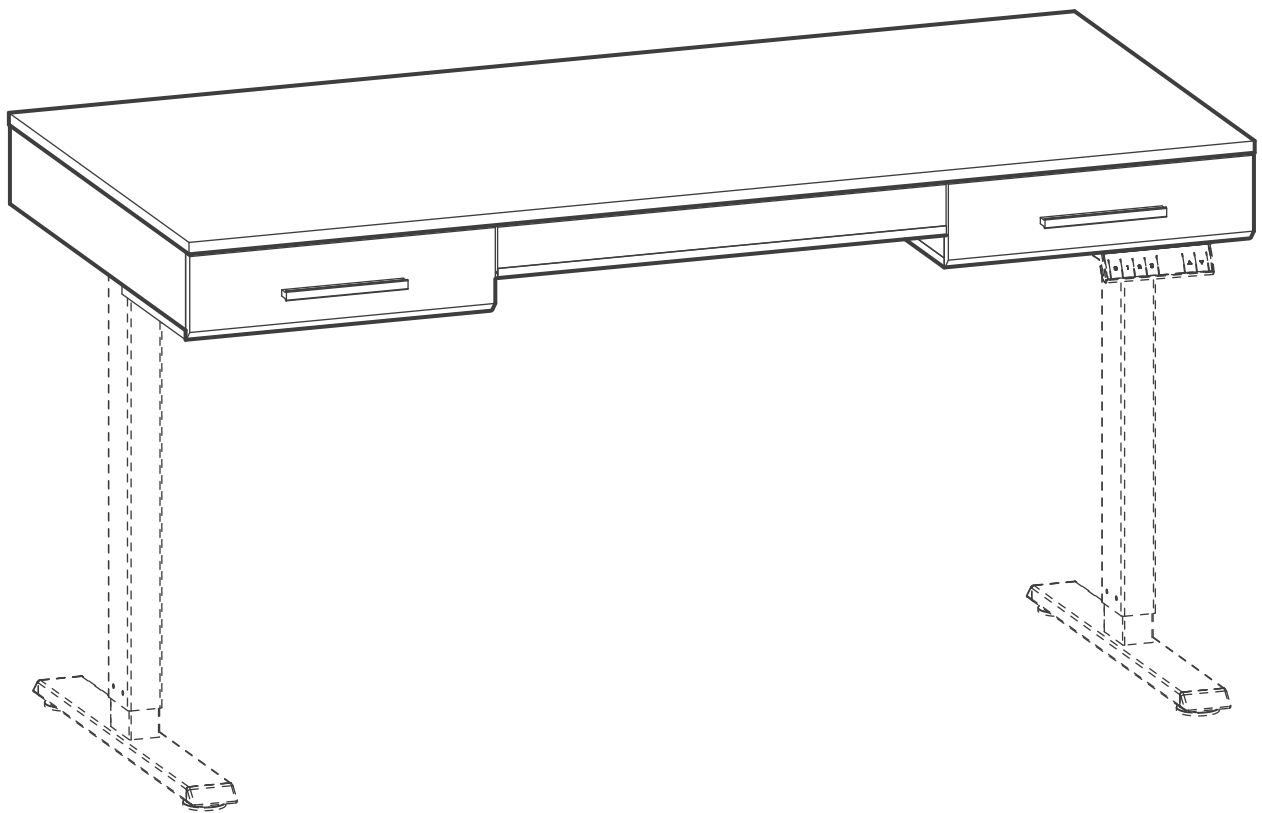

▶ Scan QR code for  
installation video



✉ support@yfs.life

🌐 yfs.life/SDE0077-ZPA



## Caution

- Before you begin: Lay out all parts on a clean surface to check if the tags and numbers are correct.
- Please use the screws correctly, otherwise you might damage the desk panel.
- Don't screw tightly before all the screws are put into the corresponding holes.
- Please make sure the product has been installed correctly and read the instructions before using the product.
- Do not use corrosive or abrasive materials to clean this product.
- The company does not bear any warranty or liability for damage and human injury caused by any abnormal or un-intended operation of the equipment.

## Pre-Installation Preparation

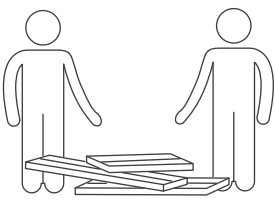
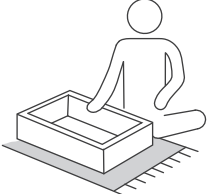
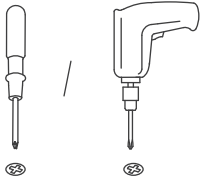
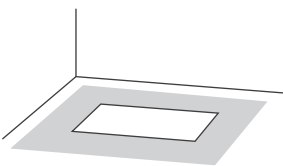



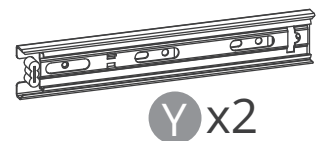
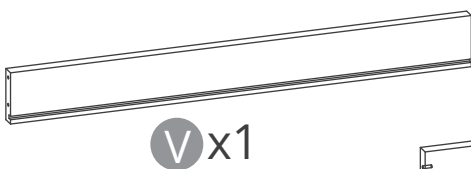
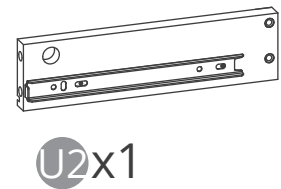
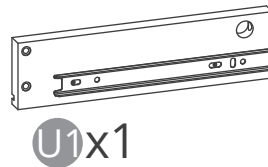
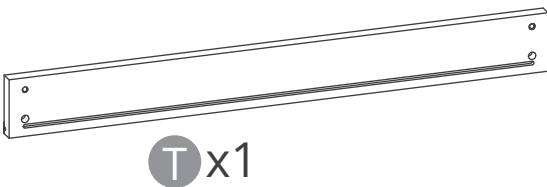
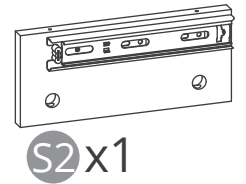
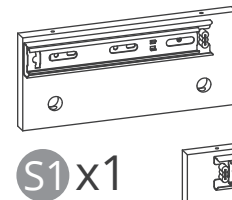
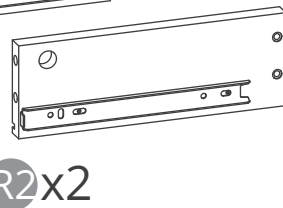
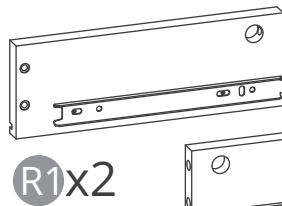
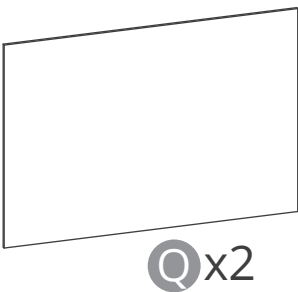
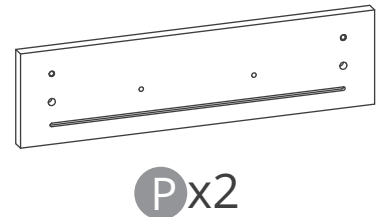
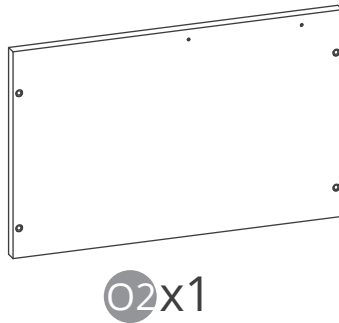
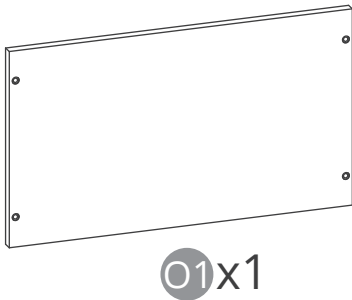
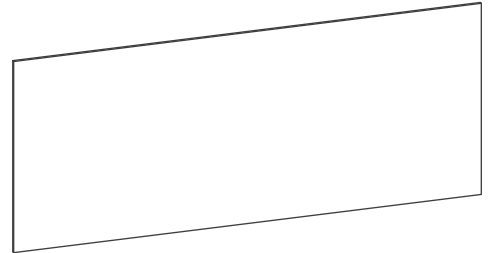
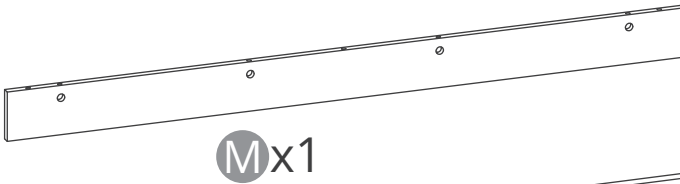
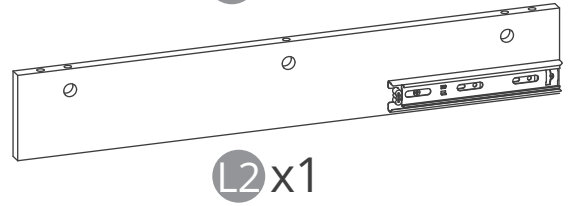
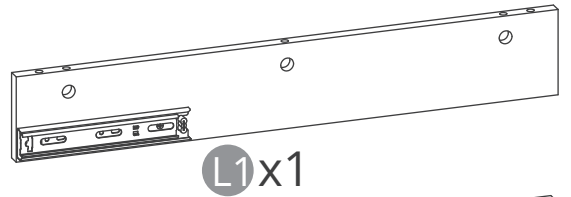
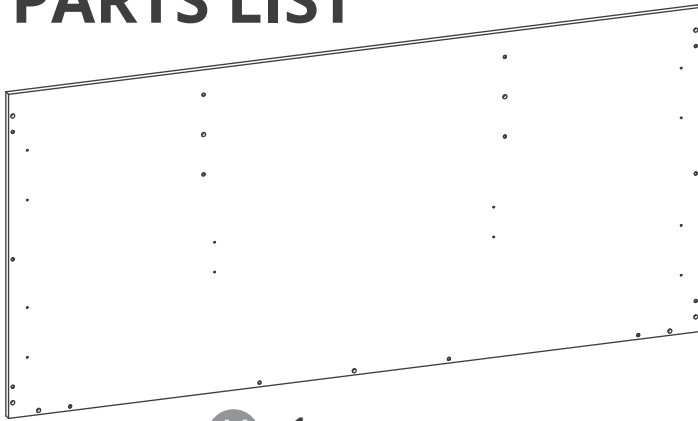

 <p>Complete through collaboration.</p>	 <p>Assemble on a clean, flat, and protective surface.</p>	 <p>Phillips screwdriver or drill required (not provided).</p>	 <p>Allow an assembly area at least twice the desktop size.</p>
--	---	--	--

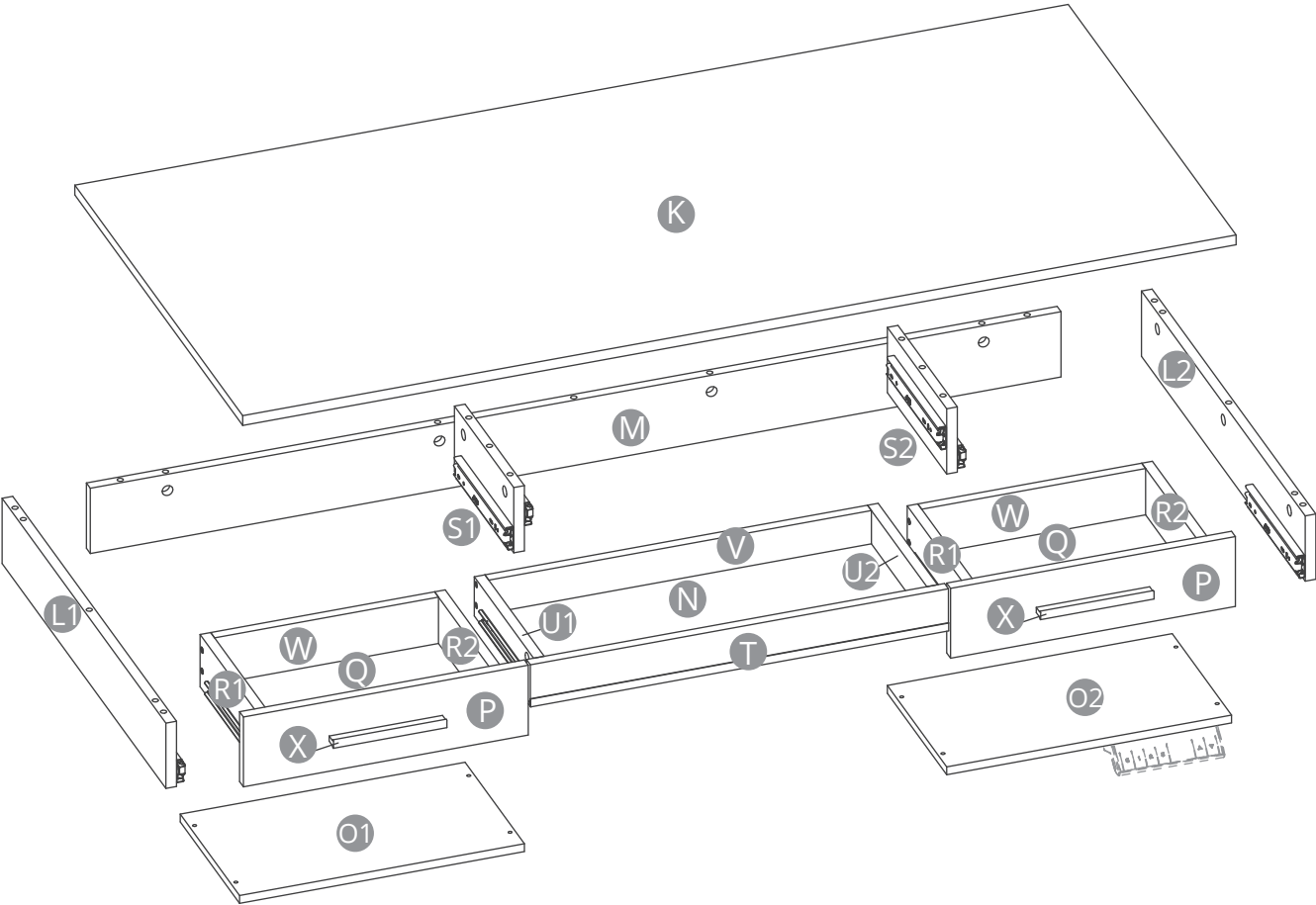
# PARTS LIST

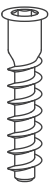
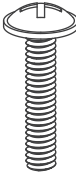

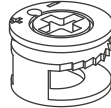
# EXPLODED VIEW DIAGRAM

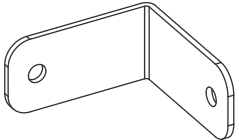

-   
**1** x20  
M7x38
  -   
**2** x4  
M4x18
  -   
**4** x15  
Ø8x30
  -   
**5** x20
  -   
**6** x20
  -   
**7** x4  
M3.5x12
- 
-   
**8** x1  
M4
  -   
**10** x16  
M5x14
  -   
**11** x2



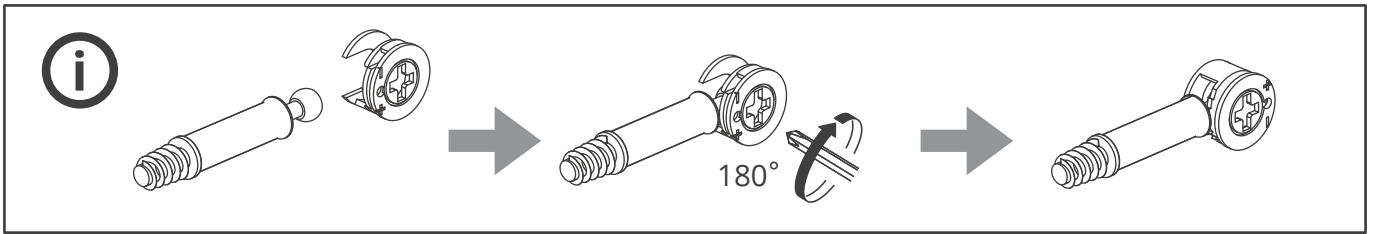

**1** **Note:** Please place the desktop on the carpet for installation to prevent scratching the desktop. The recommended screw torque for locking the tabletop is 6-8 N·m; please keep the screws perpendicular to the mounting surface during installation.

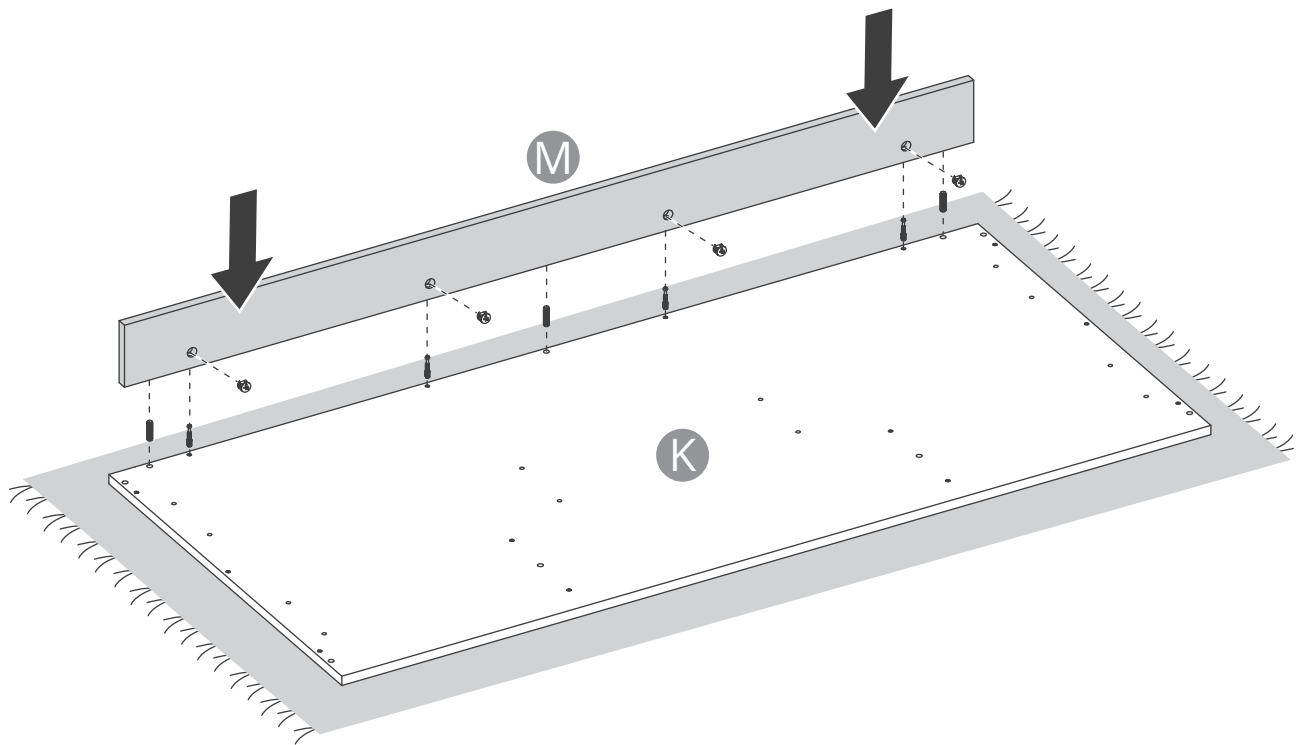
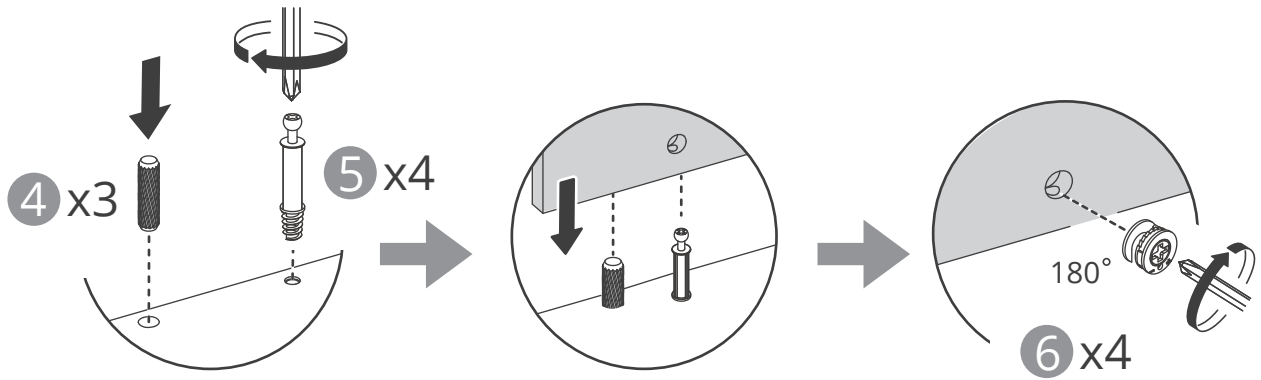

**2** The recommended screw torque for locking the tabletop is 6-10 N·m; please keep the screws perpendicular to the mounting surface during installation. This will result in a flatter tabletop.

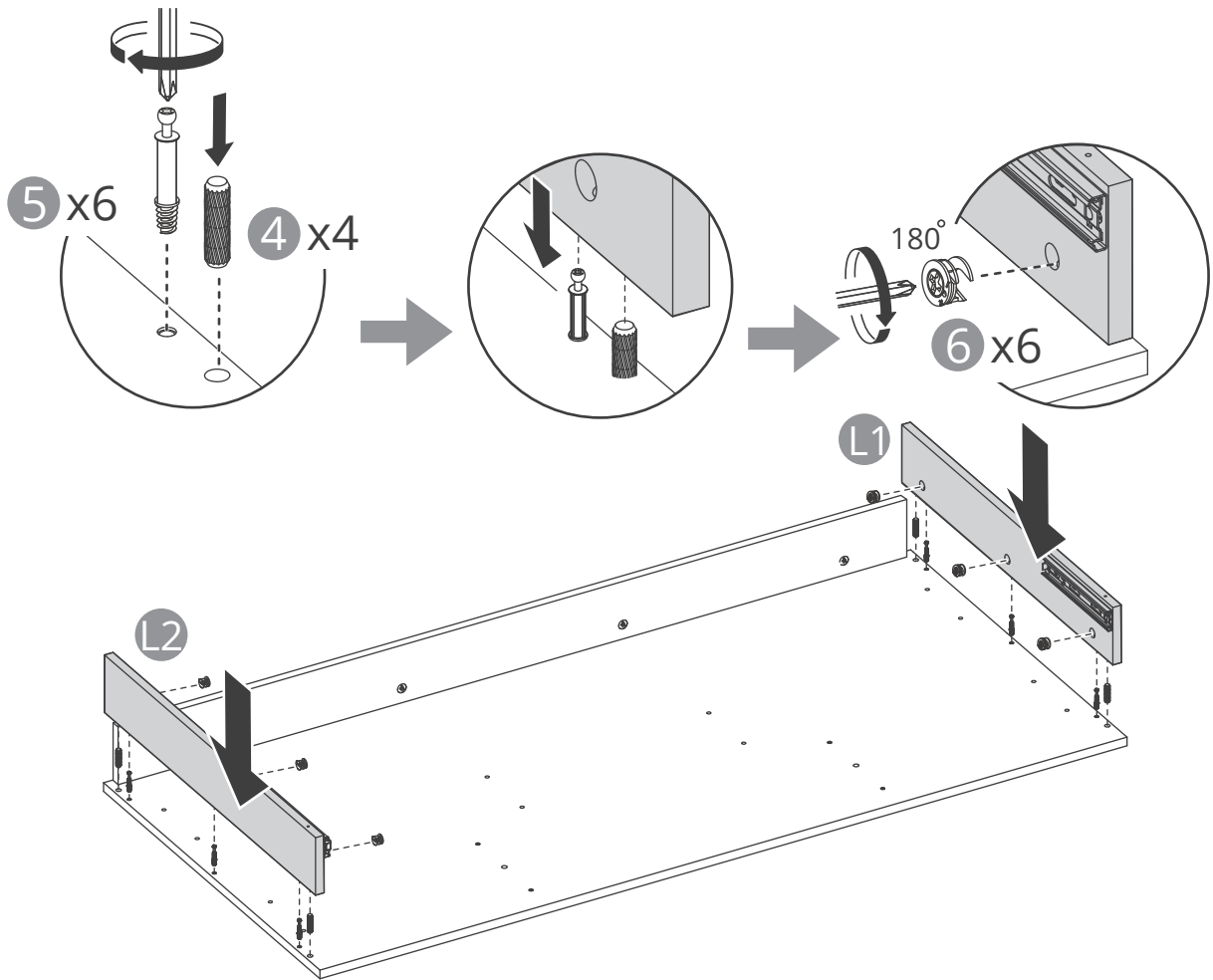

**3**

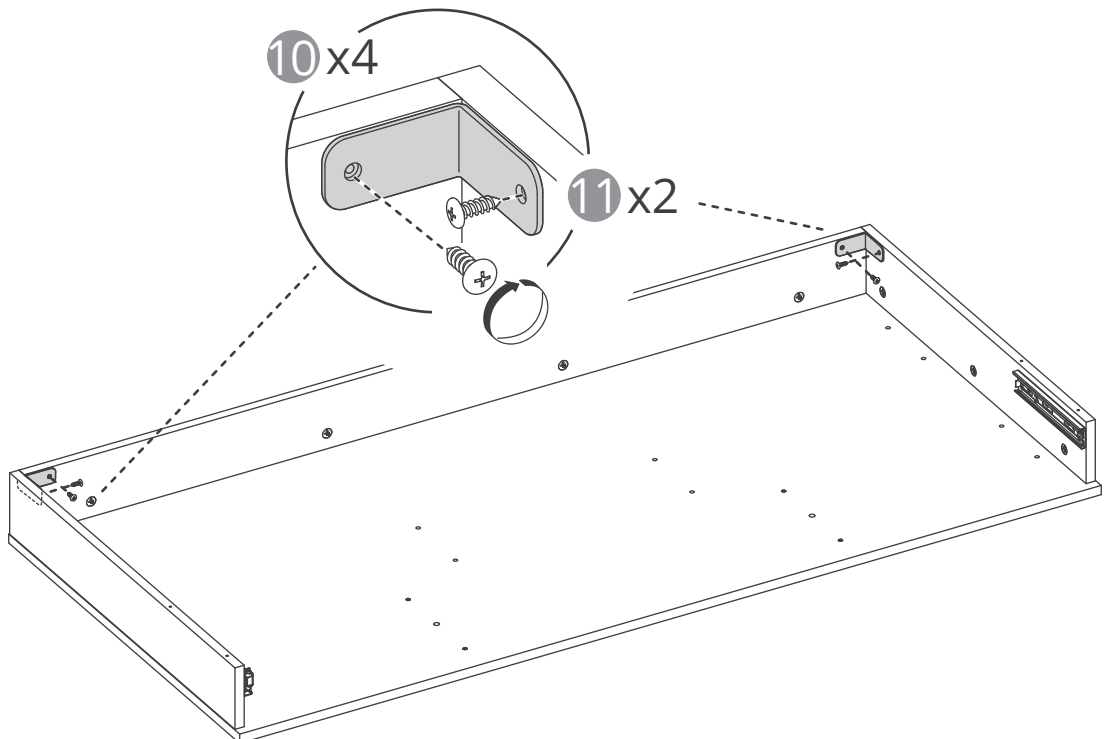



Please note: the deskframe below is for assembly reference only.  
The actual deskframe is subject to your own selection.



4

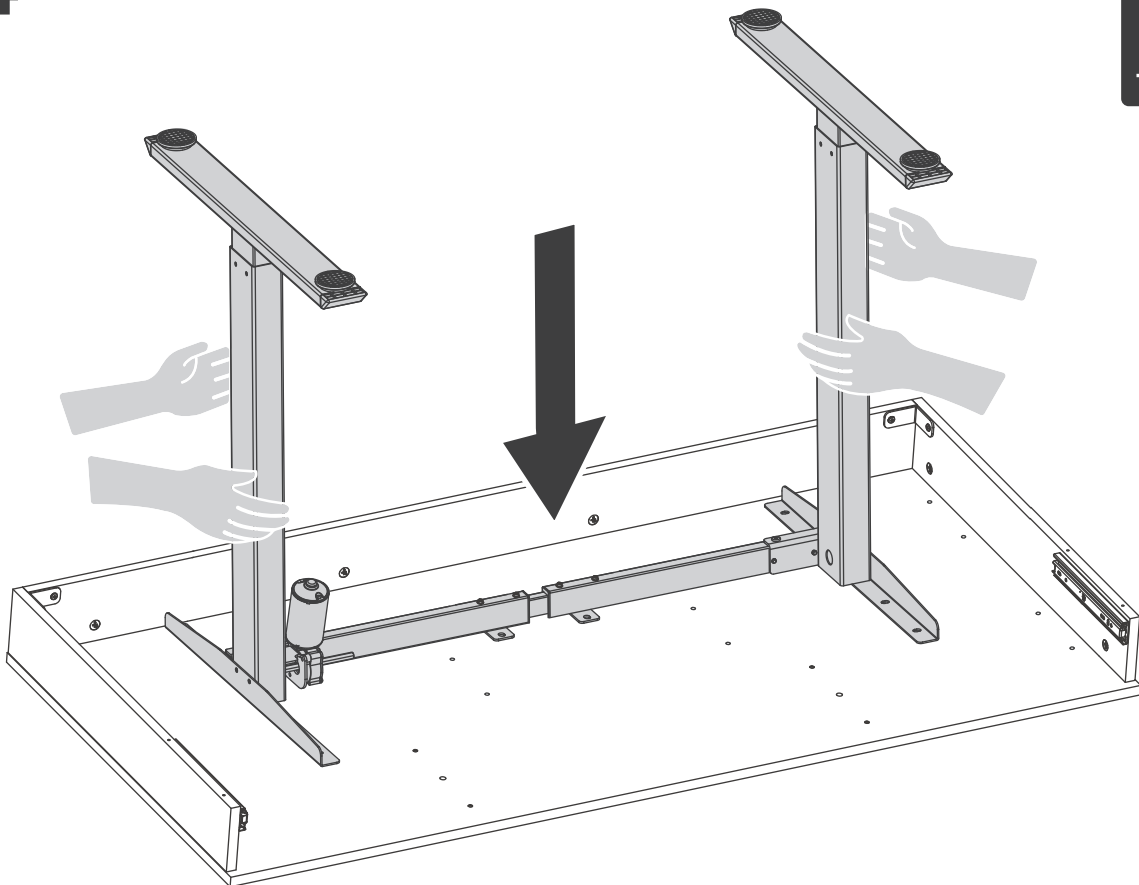

# 5

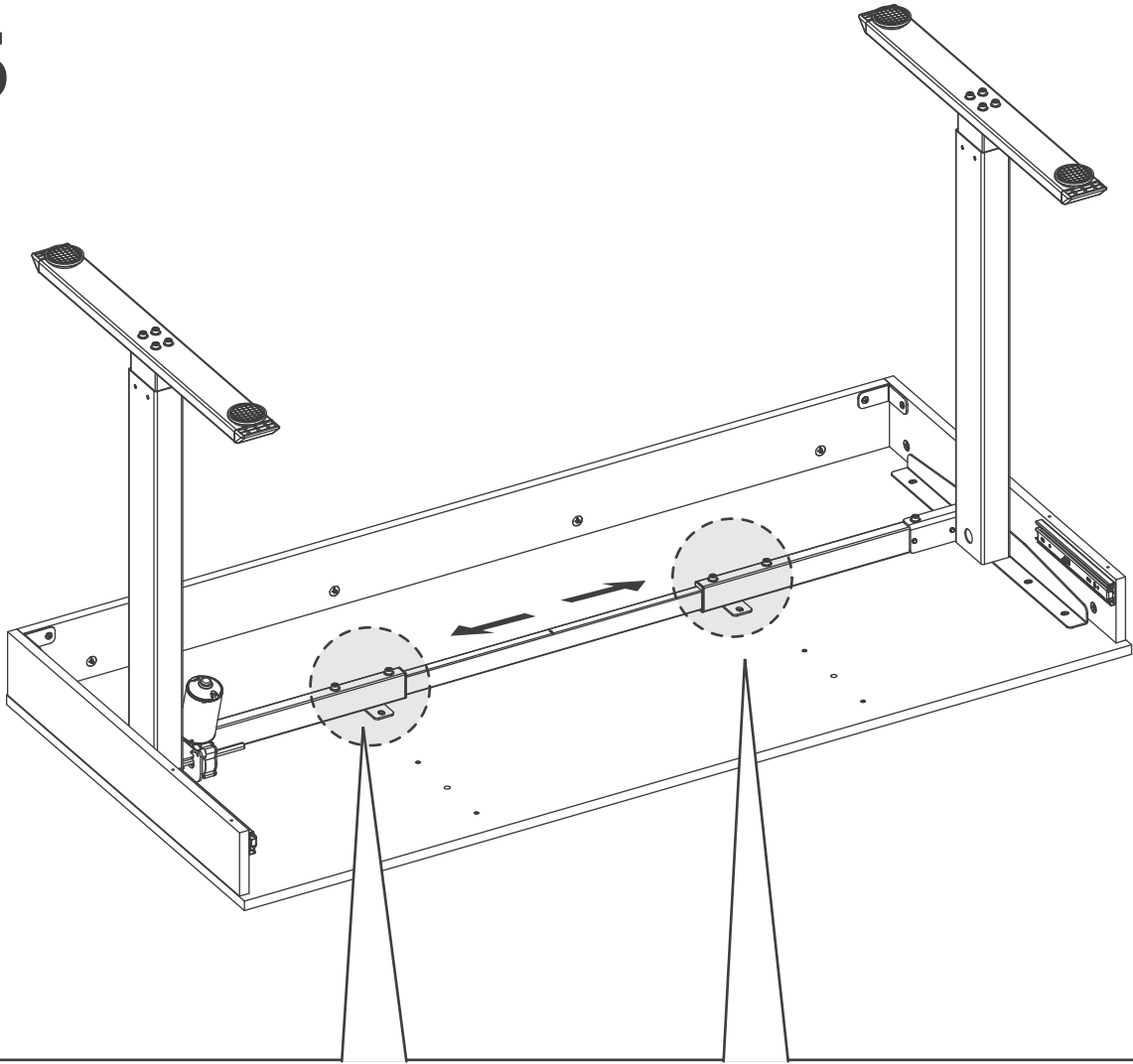

**1** Loosen the 4 screws.

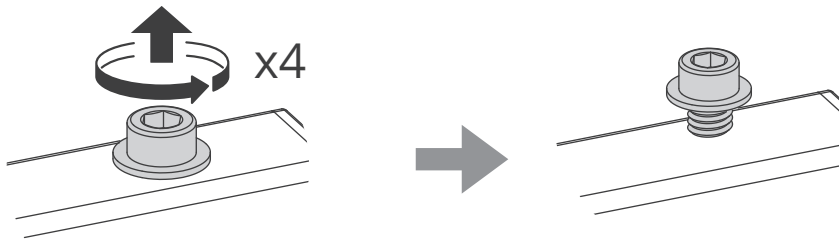

**2**

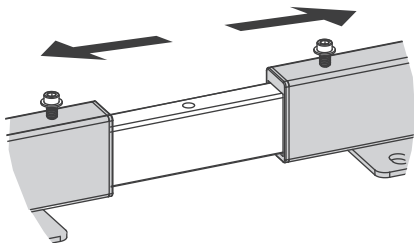

**3**

Adjust the crossbar to the center position as shown.

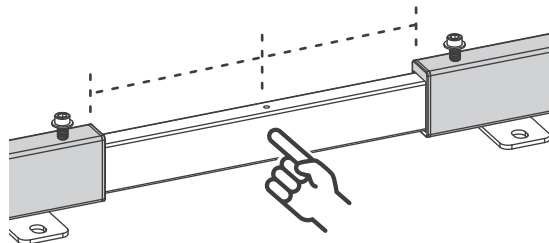

6

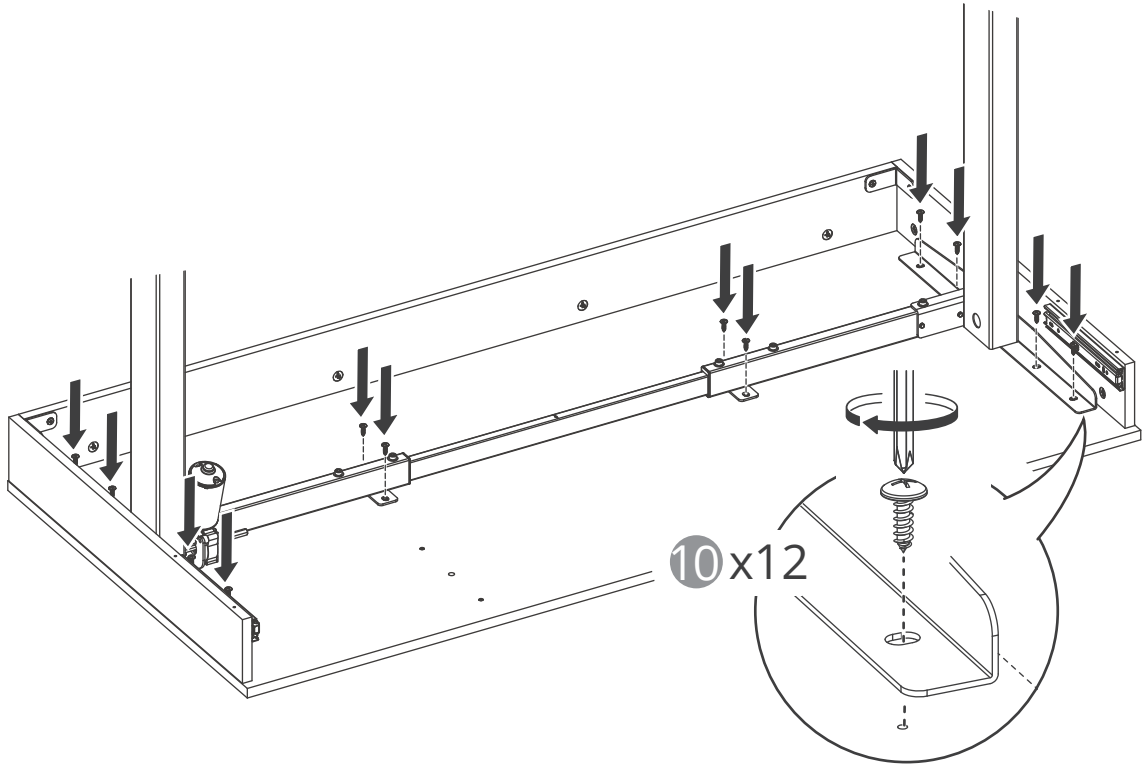

7

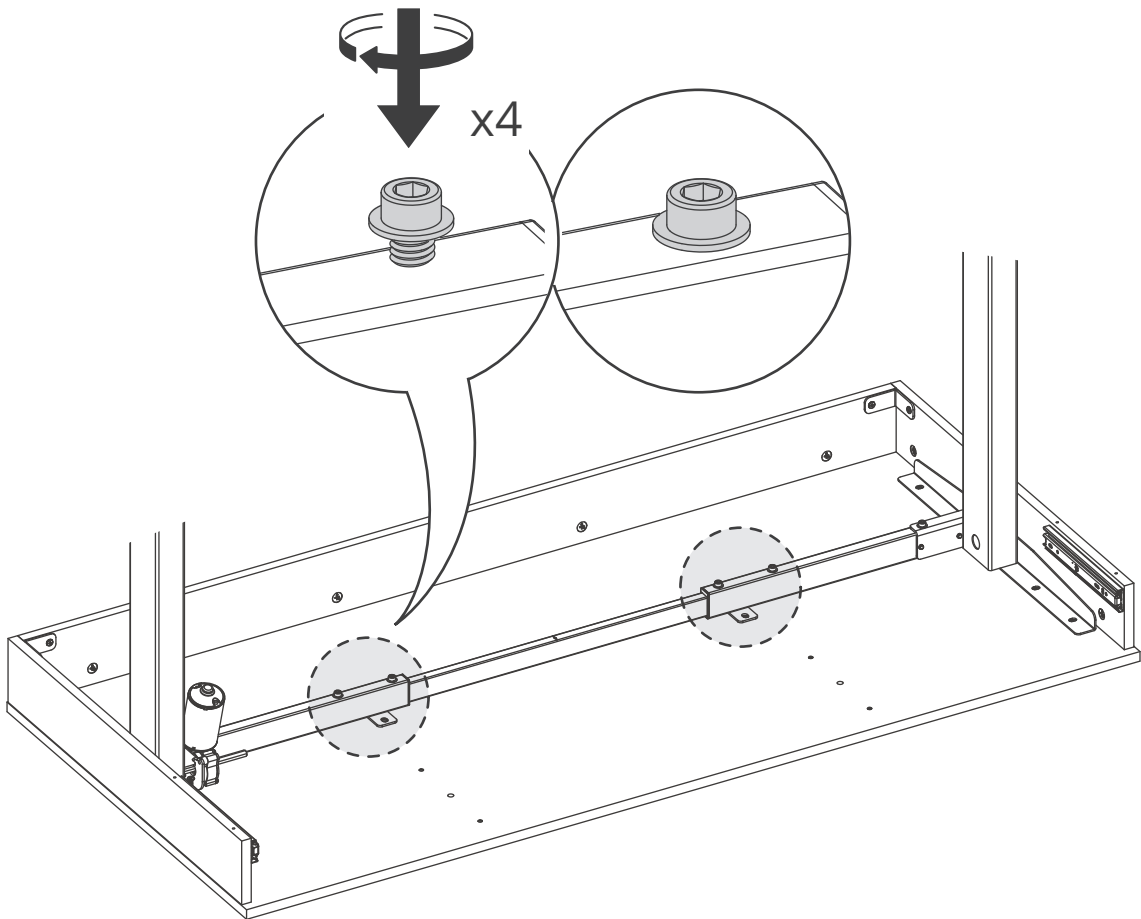

8

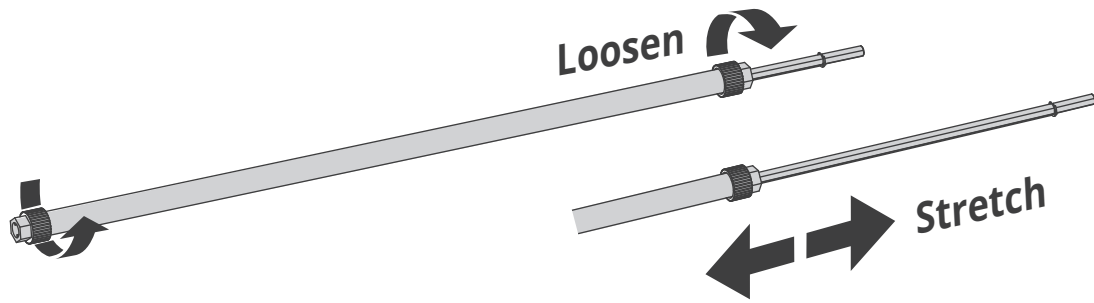

9

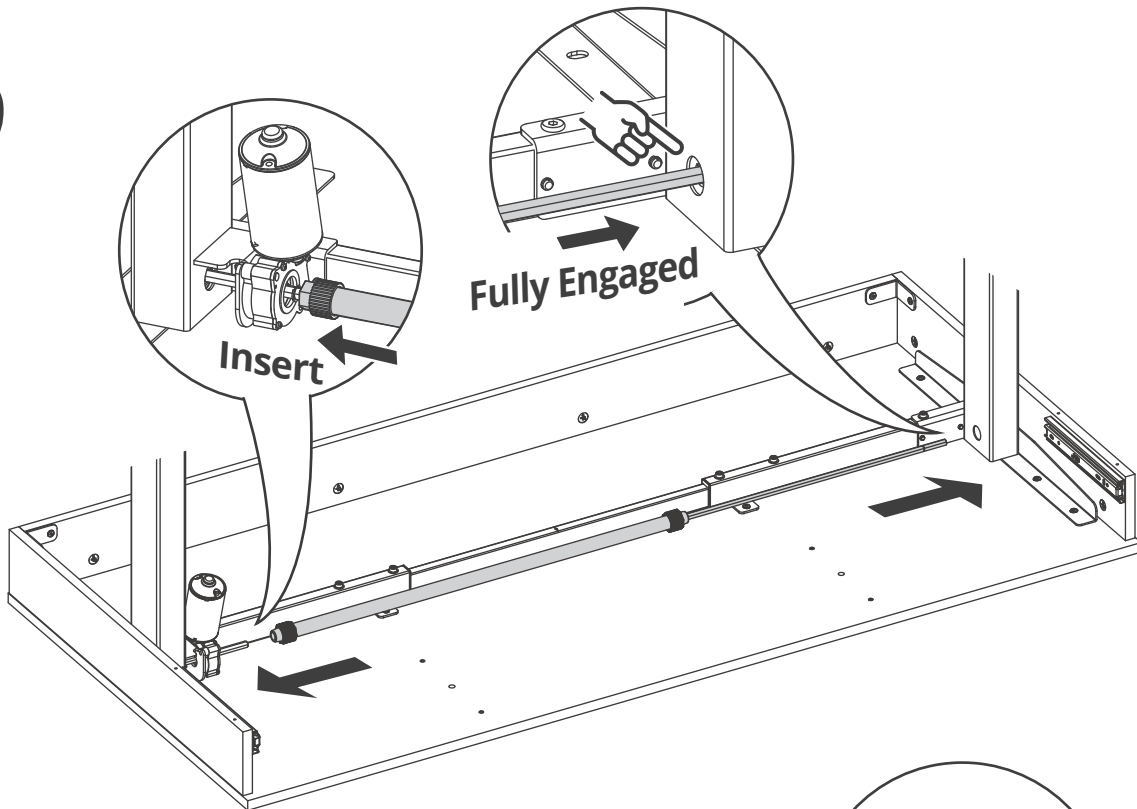

10 Ensure both ends of the sync rod are correctly positioned and fully engaged before tightening the locking sleeves.

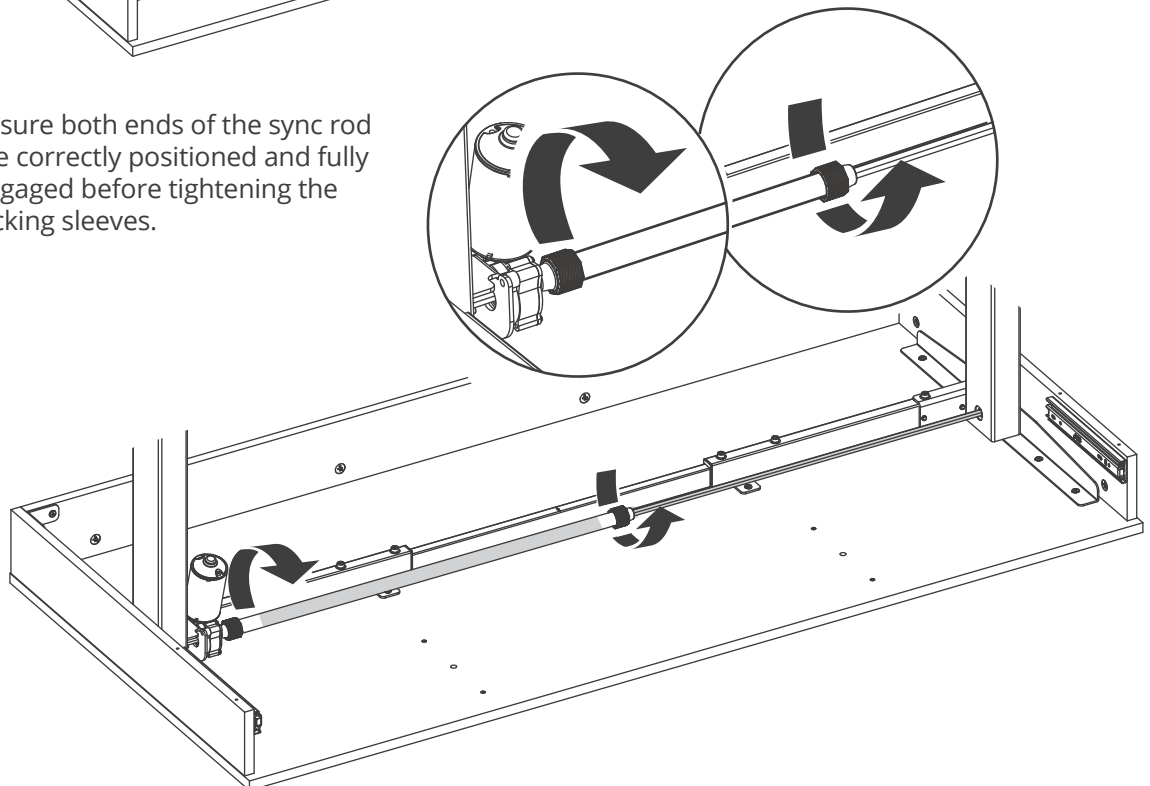

# 11

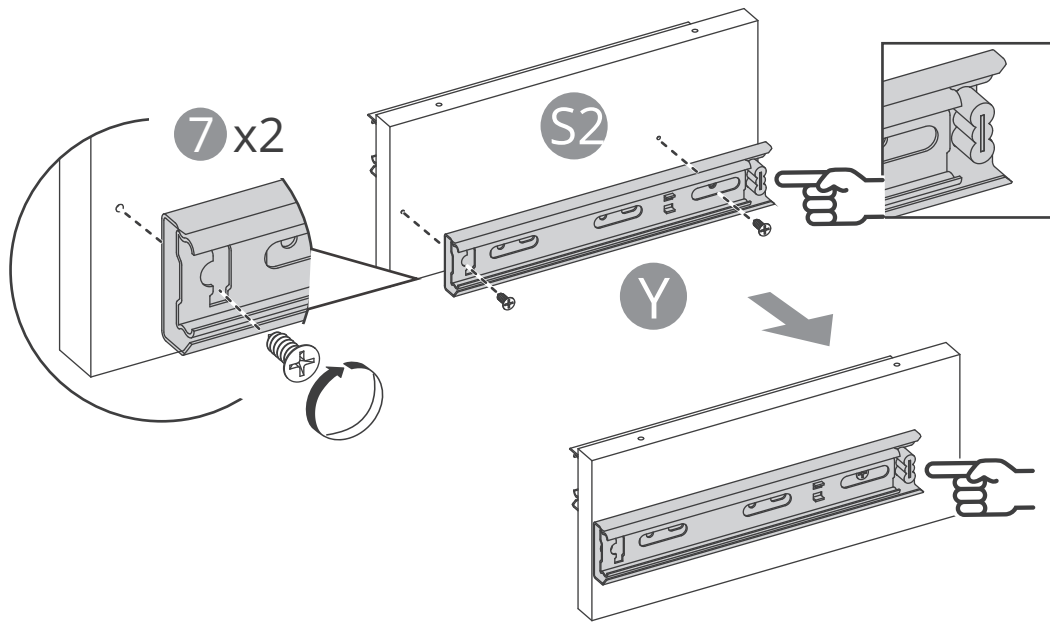

# 12

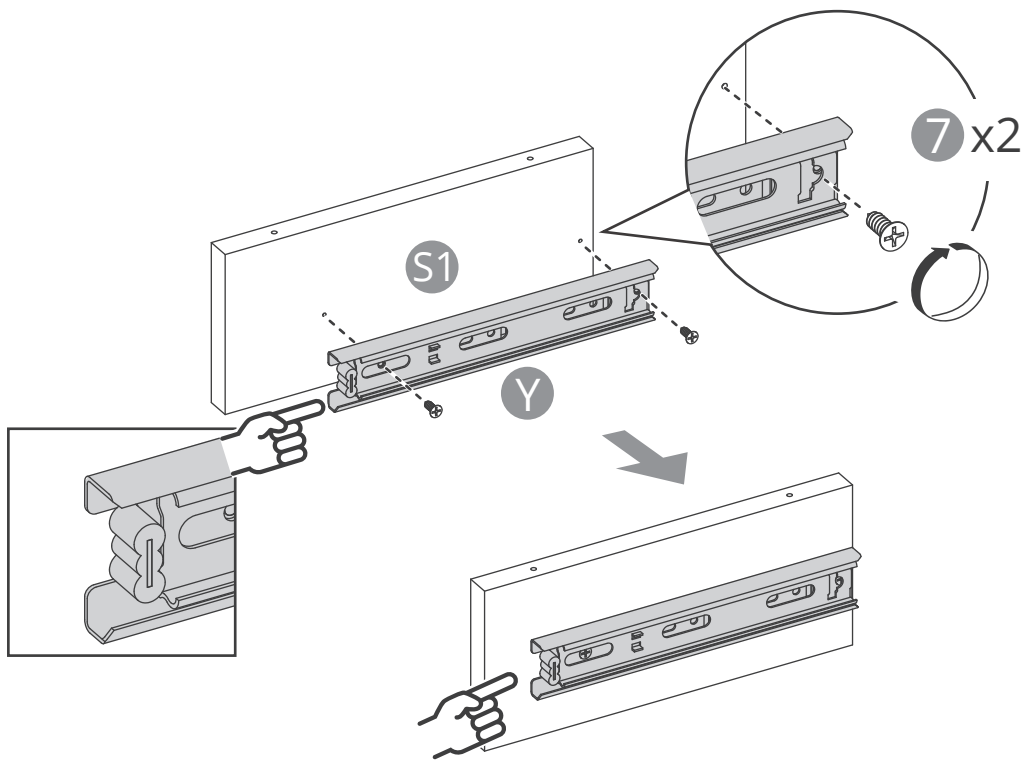

# 13

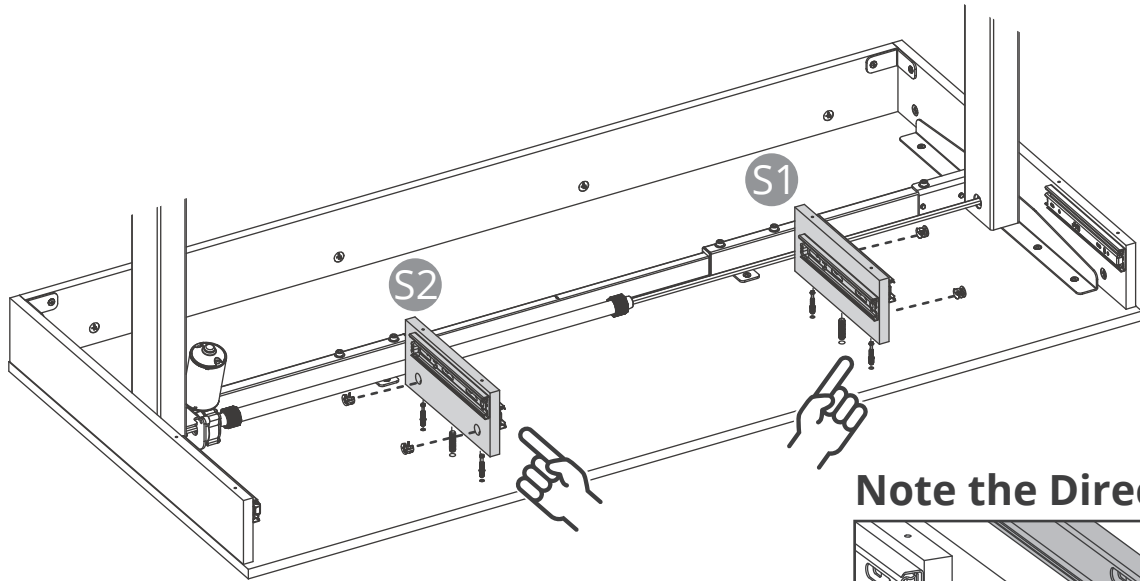
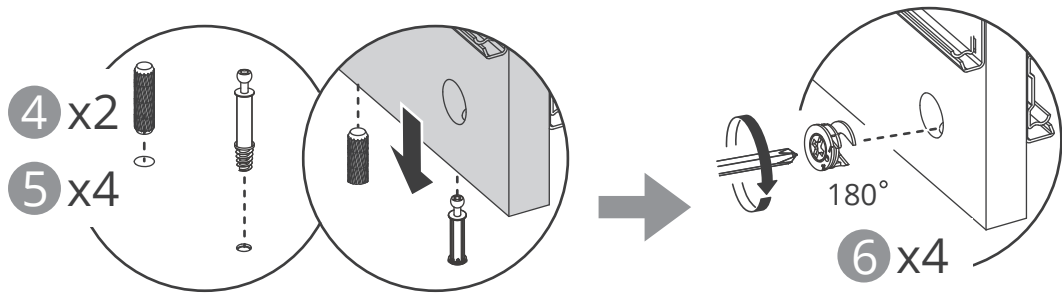

**Note the Direction**

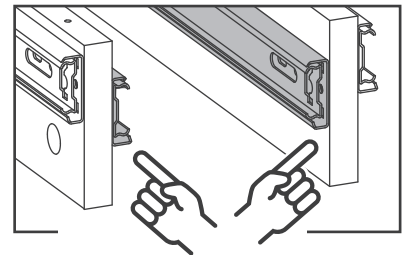

# 14

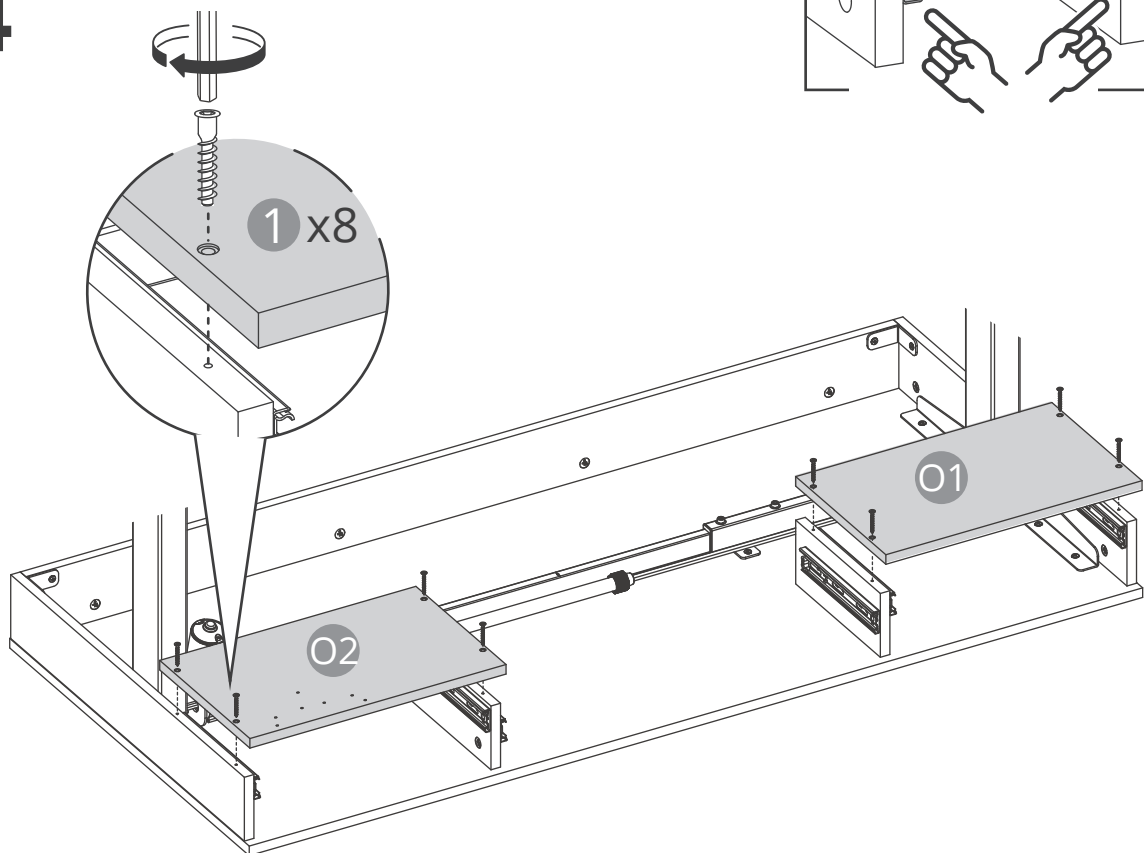



**15** The recommended screw torque for locking the tabletop is 6-10 N·m; please keep the screws perpendicular to the mounting surface during installation. This will result in a flatter tabletop.

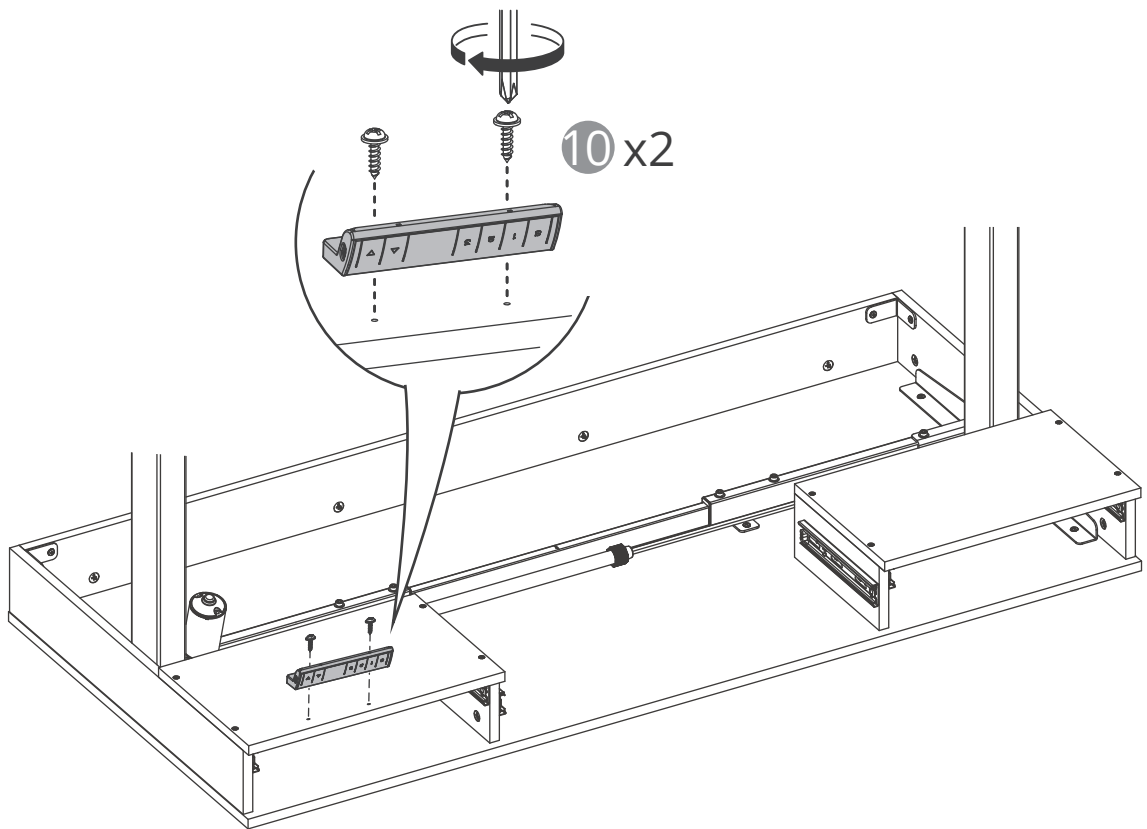

**16**

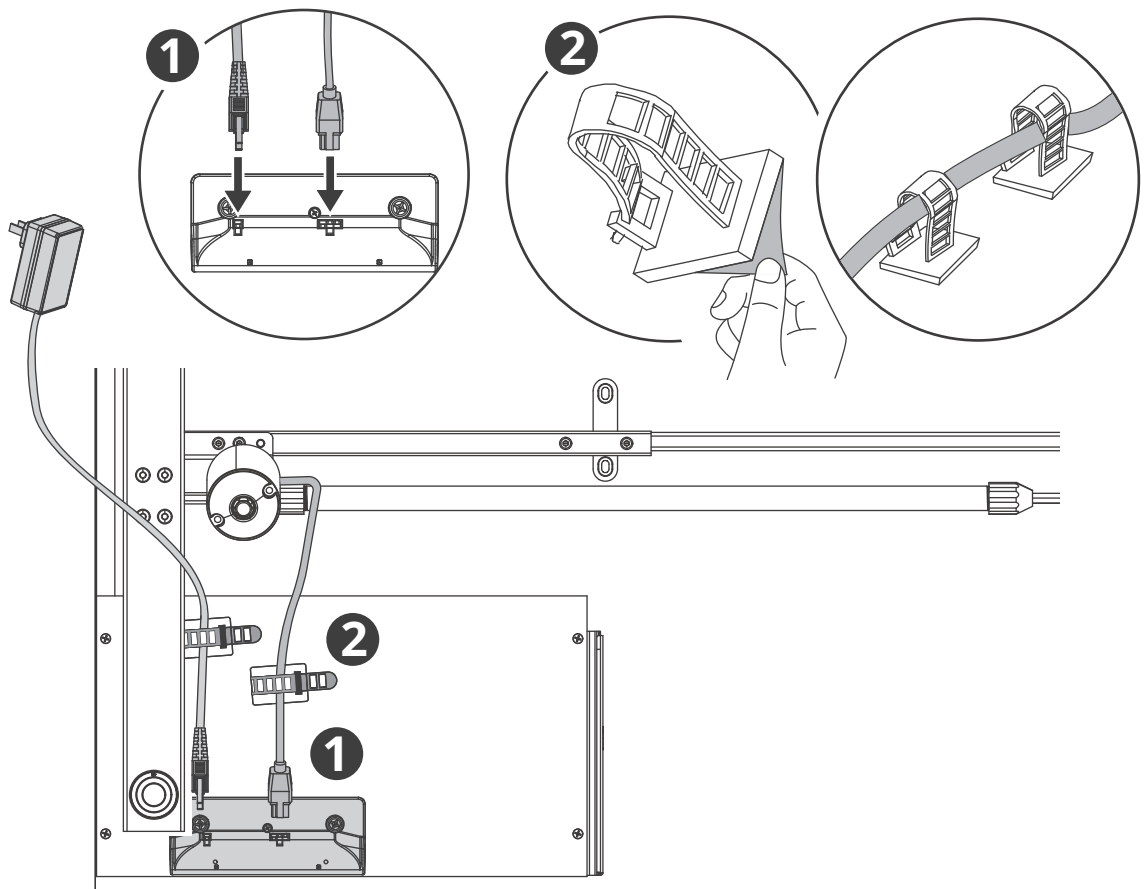

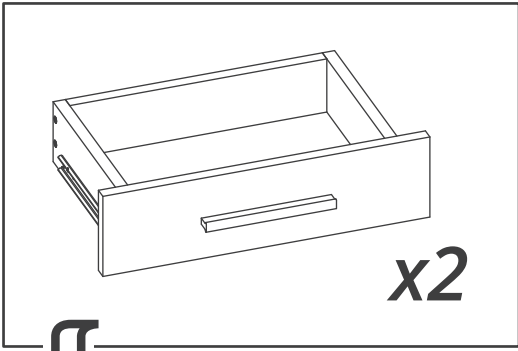

17

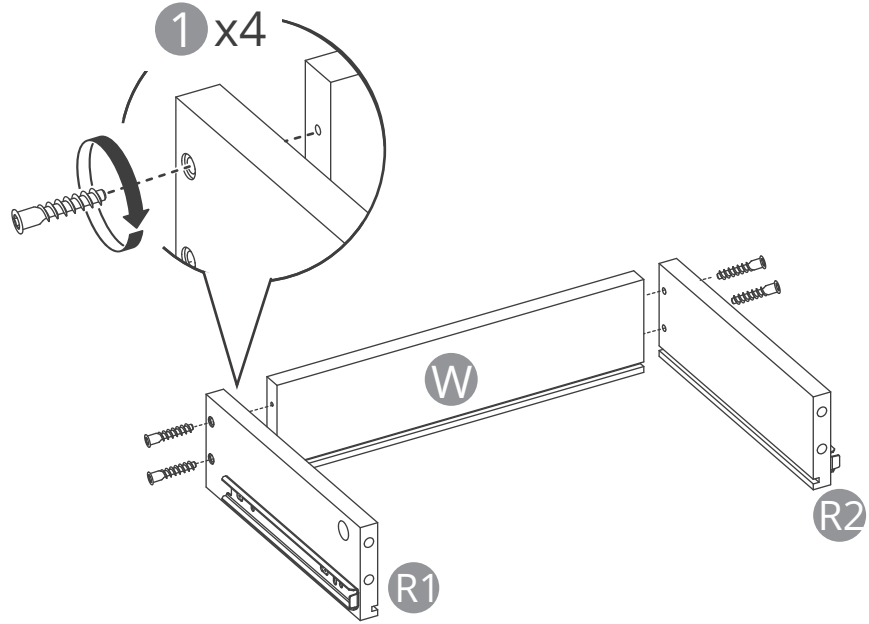

18

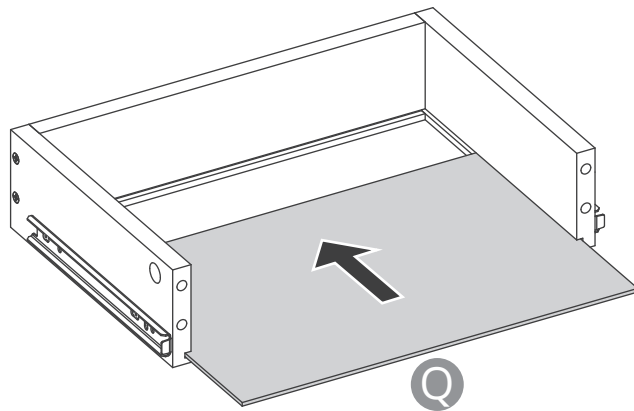

# 19

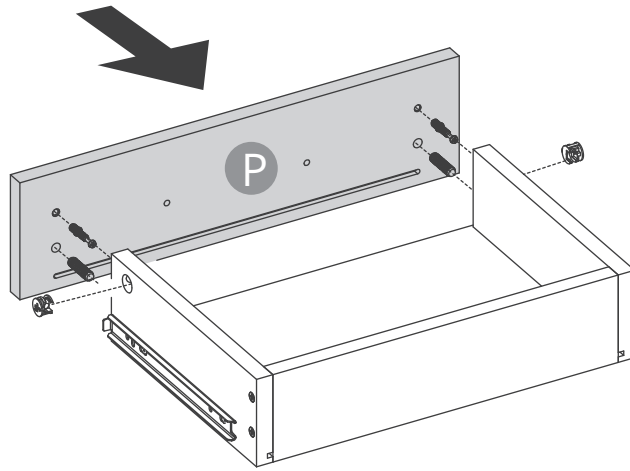
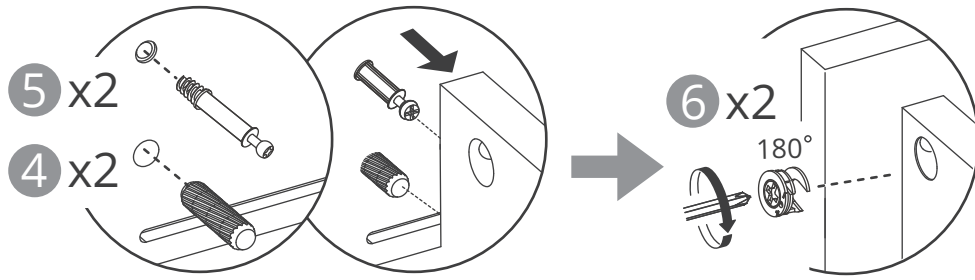

# 20

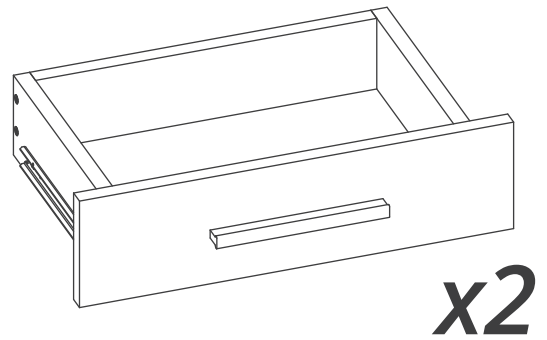
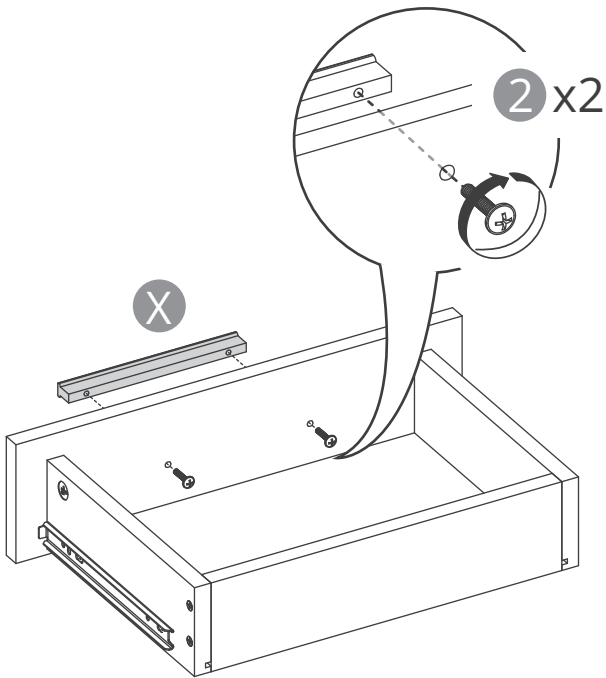

# 21

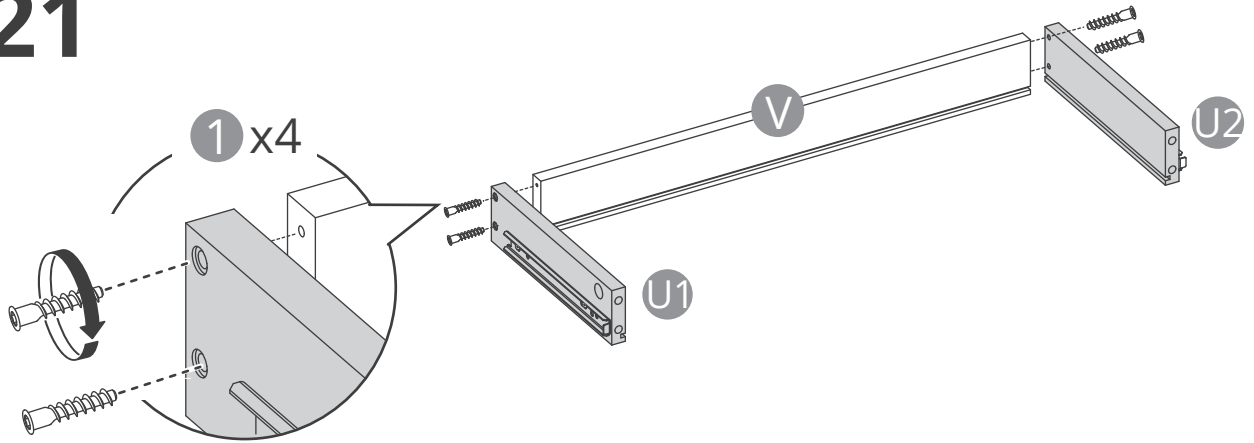

# 22

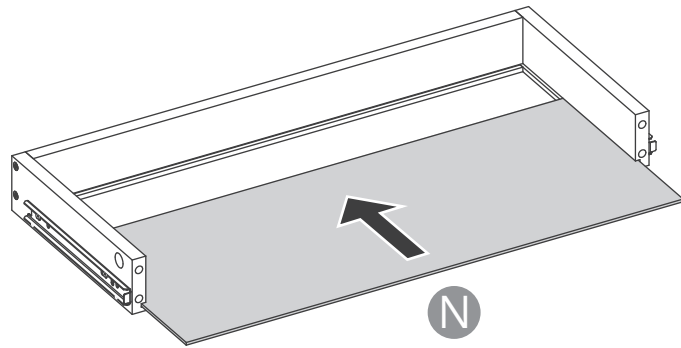

# 23

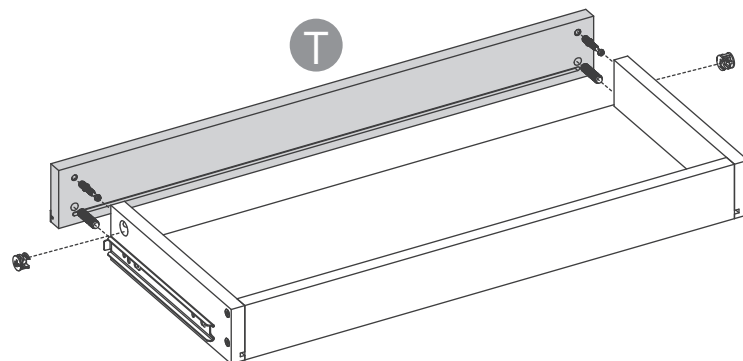
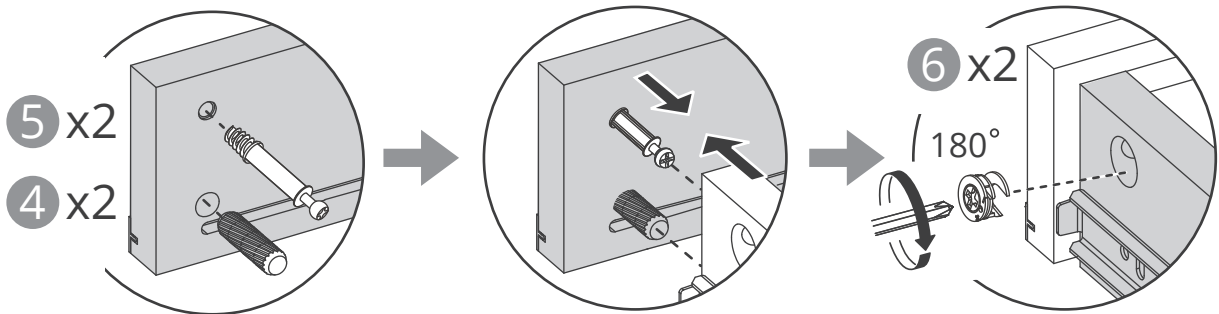

# 24 Drawer Installation

1. Pull the desk rails out fully and slide the inner mechanism to the front towards you.
2. Align drawer rails with desk rails.
3. Push drawer in gently.

**Note: Never force the drawer. If it jams, remove and realign.**

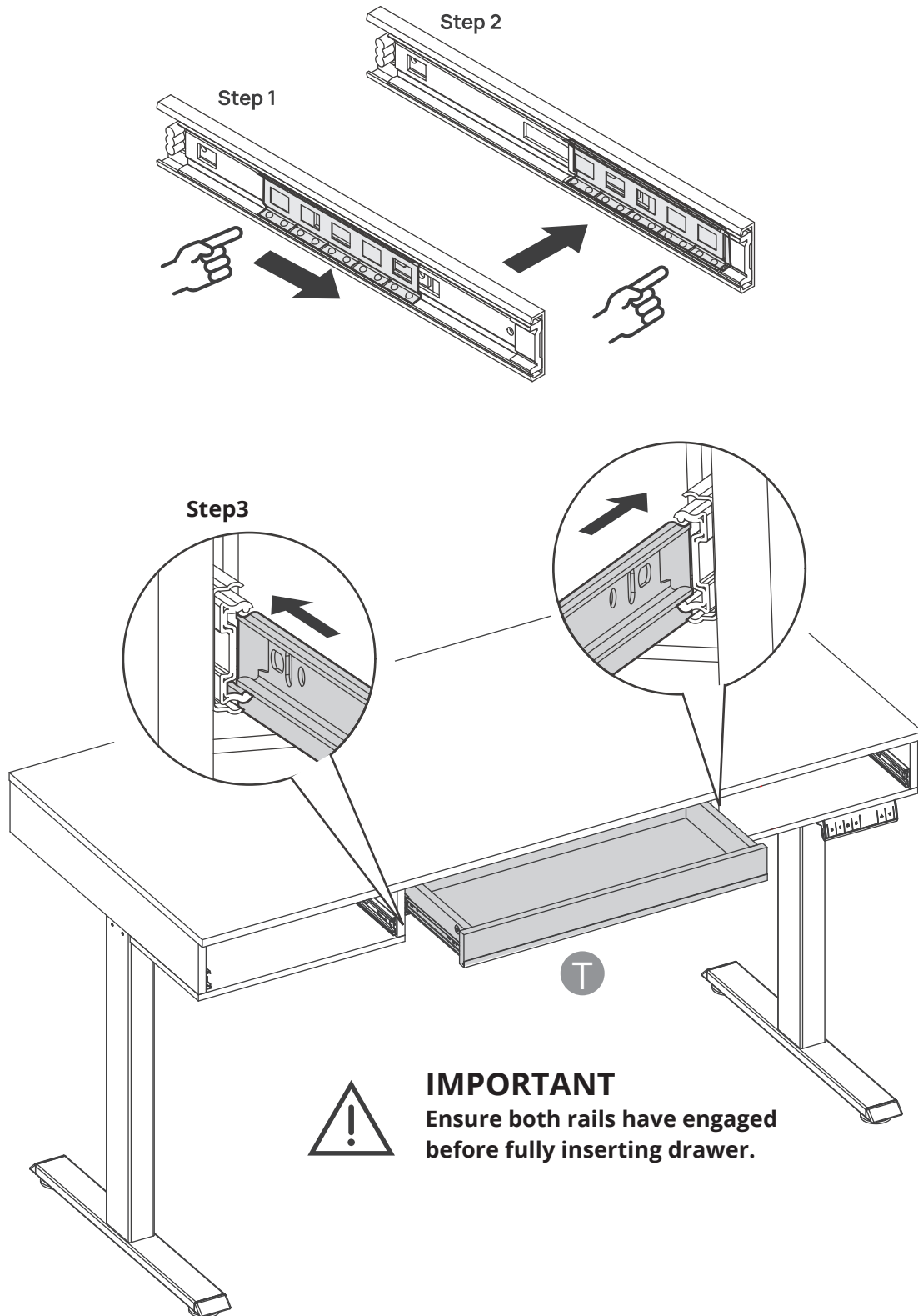

# 25 Drawer Installation

1. Pull the desk rails out fully and slide the inner mechanism to the front towards you.
2. Align drawer rails with desk rails.
3. Push drawer in gently.

**Note: Never force the drawer. If it jams, remove and realign.**

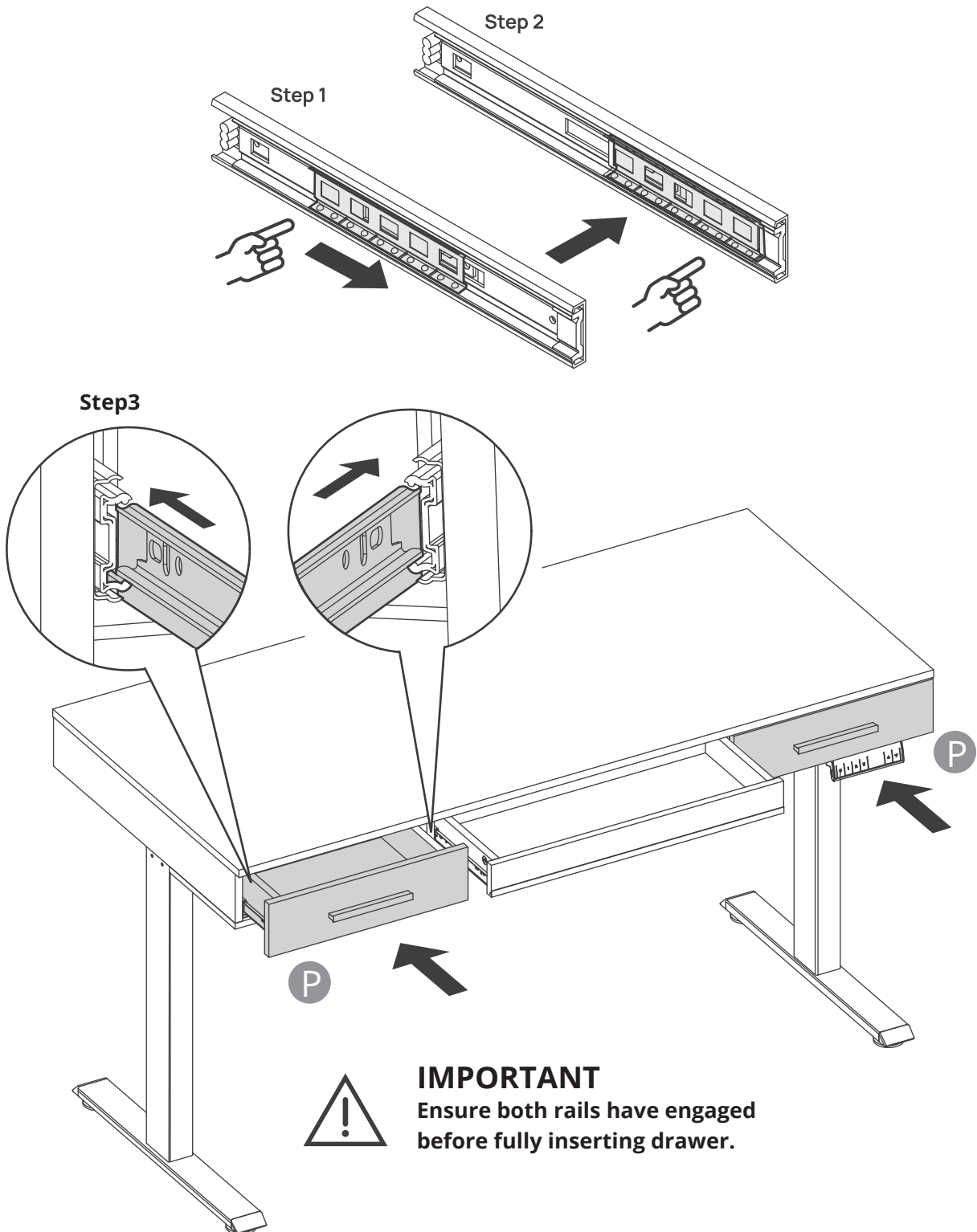

26

