

ASSEMBLY INSTRUCTIONS

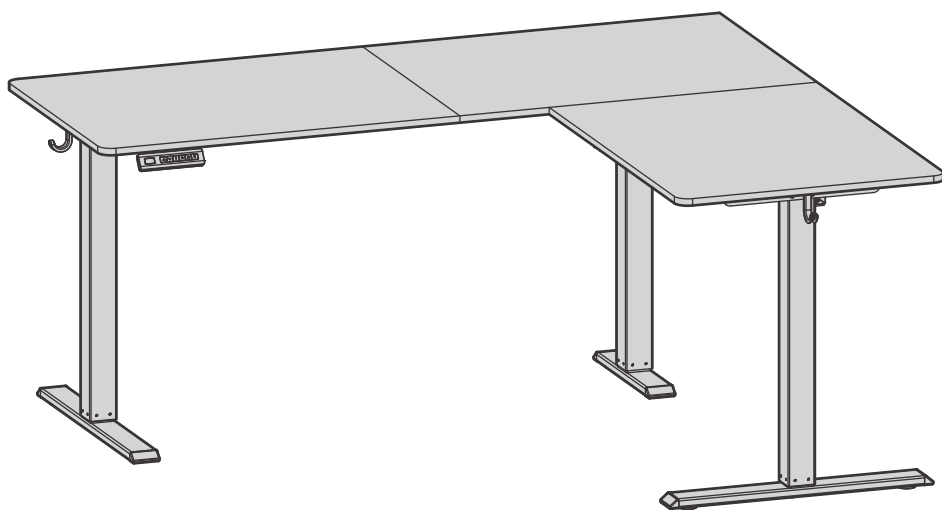

▶ Scan QR code for
installation video

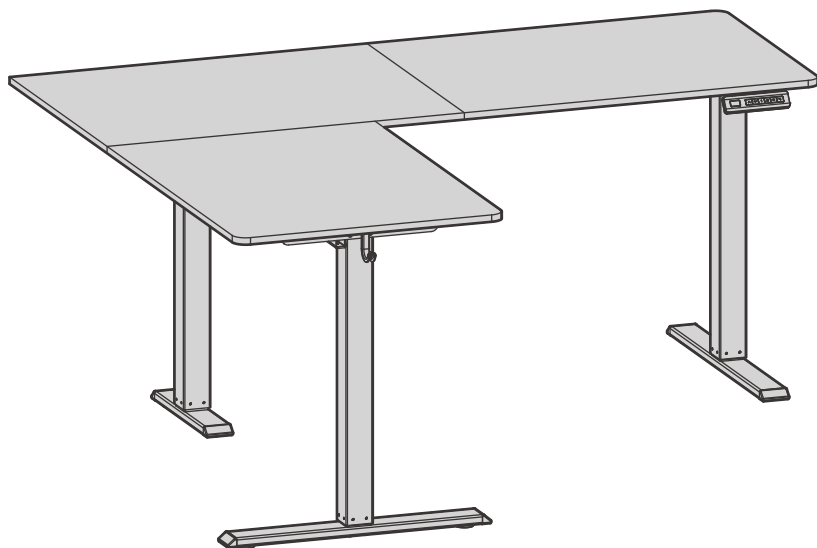

For assembly assistance,
✉ support@yfs.life 🌐 yfs.life/sde0028-j1

English

Caution

- Keep children and animals away from the desk during use. Ensure the desktop is not touching any walls.
- Remove obstacles taller than 20"/51cm from underneath the desk.
- Operate only in a working environment temperature of 32°F-104°F/0°C-40°C.
- Keep product away from corrosive gases, liquids and dusty objects.
- Keep hands, feet and other body parts in a safe position during operation. Anti-collision is not automatically enabled during all resets.
- The company does not bear any warranty or liability for damage and human injury caused by any abnormal or un-intended operation of the equipment.
- It is necessary to perform a manual reset after the initial installation or power cycling the equipment.

Español

Precaución

- Mantenga a los niños y animales alejados del escritorio durante su uso. Asegúrese de que el escritorio no toca ninguna pared.
- Retire aquellos obstáculos con una altura superior a 20"/51cm de debajo del escritorio.
- Opérela únicamente en una temperatura del entorno de trabajo de 32°F-104°F/0°C-40°C.
- Mantenga el producto alejado de gases corrosivos, líquidos y objetos con polvo.
- Mantenga las manos, pies y otras partes del cuerpo en una posición segura durante el funcionamiento. No se habilita la anticollisión de forma automática tras los reinicios.
- La empresa no ofrece ninguna garantía no asume ninguna responsabilidad por cualquier daño o lesión humana provocada por un funcionamiento anormal o no previsto del equipo.
- Es necesario realizar un reinicio manual tras la instalación inicial o el ciclo de encendido.

Italiano

Attenzione

- Tenere i bambini e gli animali lontani dalla scrivania durante l'uso. Assicurarsi che il piano non tocchi alcuna parete.
- Rimuovere gli ostacoli più alti di 20"/51cm da sotto la scrivania.
- Operare solo in un ambiente di lavoro con una temperatura di 32°F-104°F/0°C-40°C.
- Tenere il prodotto lontano da gas e liquidi corrosivi e oggetti polverosi.
- Tenere mani, piedi e altre parti del corpo in posizione di sicurezza durante il funzionamento. L'anti-collisione non è automaticamente attivata dopo il ripristino.
- La società non si assume alcuna garanzia o responsabilità per danni e lesioni umane causati da un funzionamento anomalo o non previsto dell'apparecchiatura.
- È necessario eseguire un ripristino manuale dopo l'installazione iniziale o il ciclo di alimentazione.

Deutsch

Vorsicht

- Halten Sie Kinder und Tiere während der Benutzung vom Tisch fern. Achten Sie darauf, dass die Tischplatte keine Wände berührt.
- Entfernen Sie Hindernisse, die höher als 20"/51cm Zoll sind, von der Unterseite des Tisches.
- Betreiben Sie das Gerät nur in einer Arbeitsumgebung mit einer Temperatur von 32°F-104°F/0°C-40°C.
- Halten Sie das Produkt von ätzenden Gasen, Flüssigkeiten und staubigen Gegenständen fern.
- Halten Sie Hände, Füße und andere Körperteile während des Betriebs in einer sicheren Position. Der Antikollisionsschutz wird nach den Zurücksetzen nicht automatisch aktiviert.
- Das Unternehmen übernimmt keine Garantie oder Haftung für Schäden und Verletzungen, die durch einen abnormalen oder unbeabsichtigten Betrieb des Geräts verursacht werden.
- Nach der Ersteinrichtung oder dem Ersteinrichten der Stromversorgung muss eine manuelle Rückstellung vorgenommen werden.

Français

Attention

- Pendant l'utilisation, gardez les enfants et les animaux à l'écart du bureau. Veillez à ce que le bureau ne touche aucun mur.
- Éliminez les obstacles de plus de 20"/51cm pouces de hauteur sous le bureau.
- N'utilisez le produit que dans un environnement de travail dont la température est comprise entre 32°F-104°F/0°C-40°C.
- Éloignez le produit de toute source de gaz corrosifs, de liquides et d'objets poussiéreux.
- Gardez les mains, les pieds et les autres parties du corps dans une position sûre lorsque vous utilisez l'appareil. L'anticollision n'est pas automatiquement activée après les réinitialisations.
- Aucune garantie ou responsabilité n'est assumée par la société pour les dommages et les blessures humaines causés par un fonctionnement anormal ou non intentionnel de l'équipement.
- Une réinitialisation manuelle est indispensable après l'installation initiale ou un cycle d'alimentation.





EN Assembly Guide

Scan the QR code for installation videos and detailed user instructions.

DE Installationsanleitung

Scannen Sie den QR-Code, um Installationsvideos und weitere Anleitungen zu erhalten!

FR Guide d'assemblage

Scannez le code QR pour obtenir des vidéos d'installation et des instructions d'utilisation détaillées.

ES Guía para el montaje

Escanee el código QR para ver videos de instalación e instrucciones detalladas de uso.

IT Guida al montaggio

Scansiona il codice QR per vedere i video di installazione e le istruzioni dettagliate per l'uso.



Select Return Configuration

Option 1

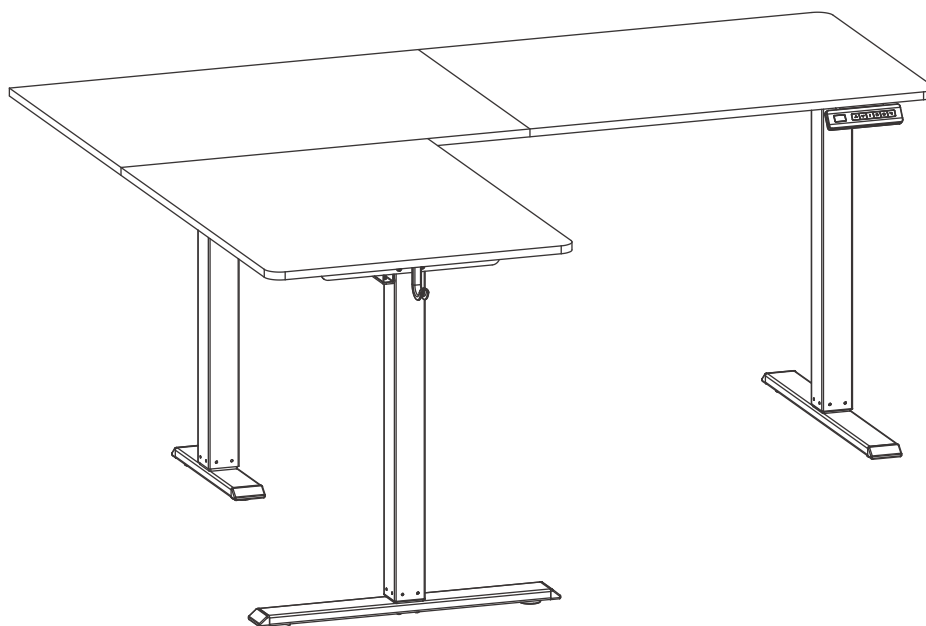

Page 6-19

Option 2

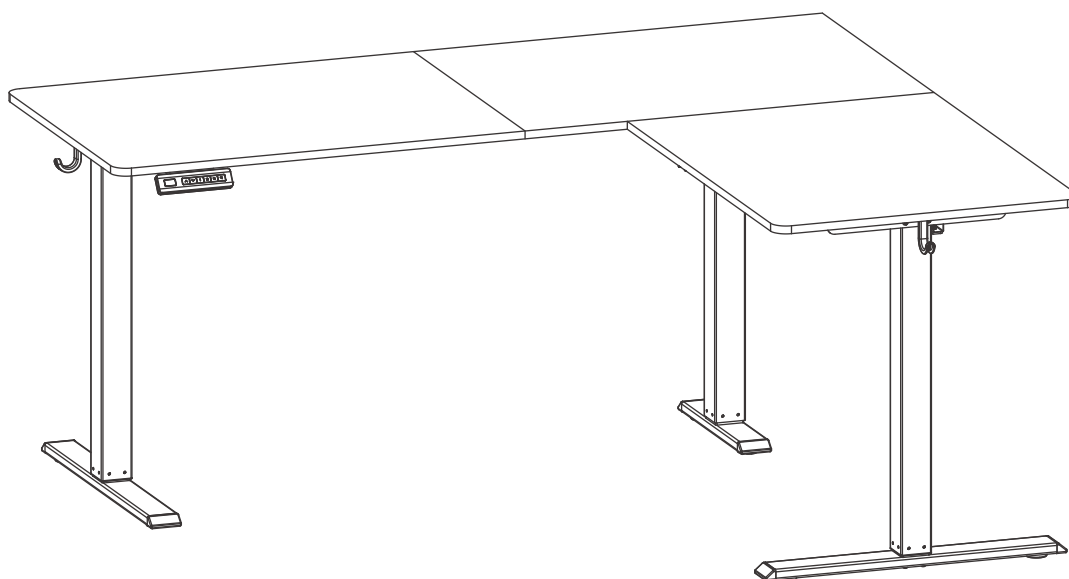

Page 20-33

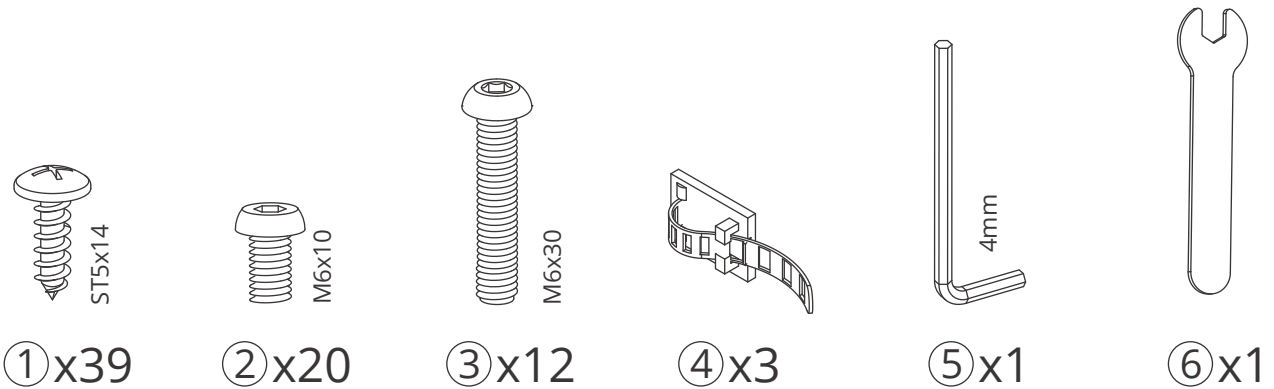
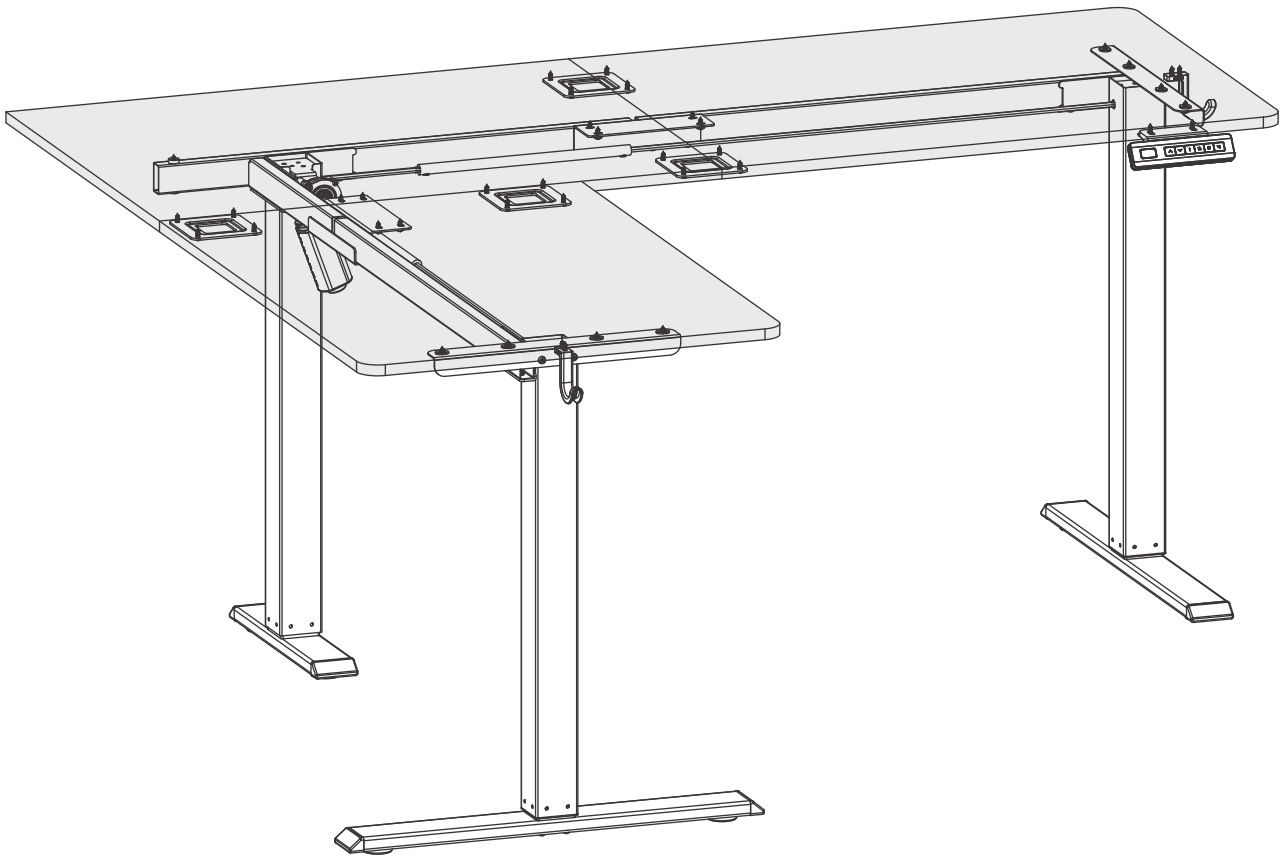
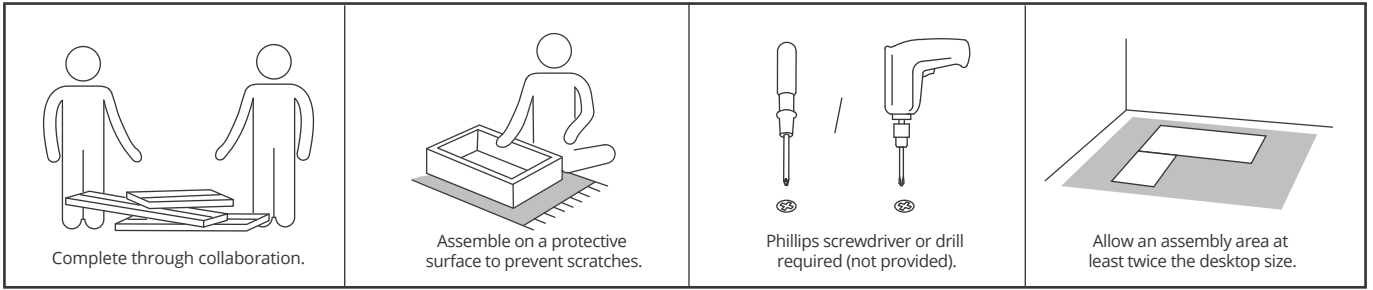

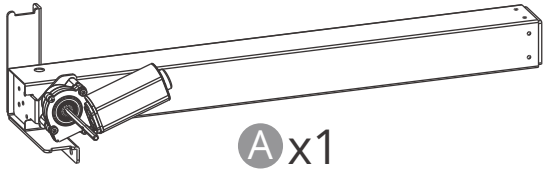

A x1



B x1



C x1

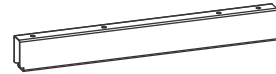

D x1



E x1

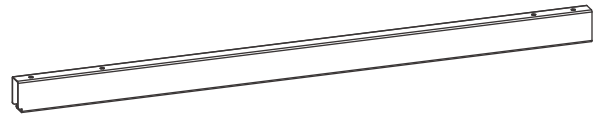

F x2

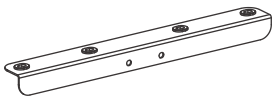

G x2

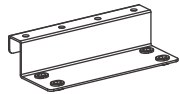

H x2



I x2

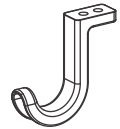

J x2



K (1+1)



L x1



M x2



N x4

Ensure the rubber pads are attached to the frame. If any have fallen off, reattach them or use the spare rubber pads.

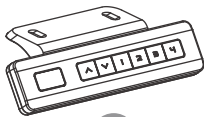

O x1

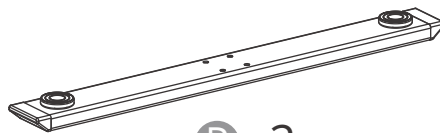

P x2

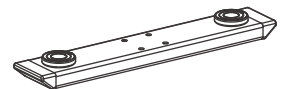

Q x1



S x1

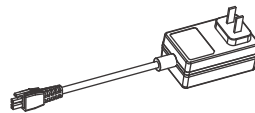

T x1



U x4

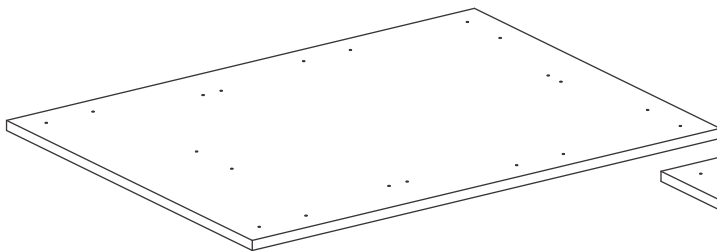

R1 x1

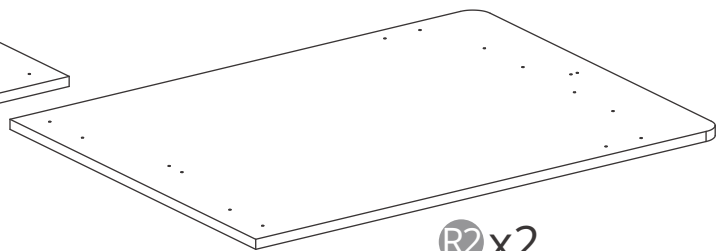

R2 x2

Option 1

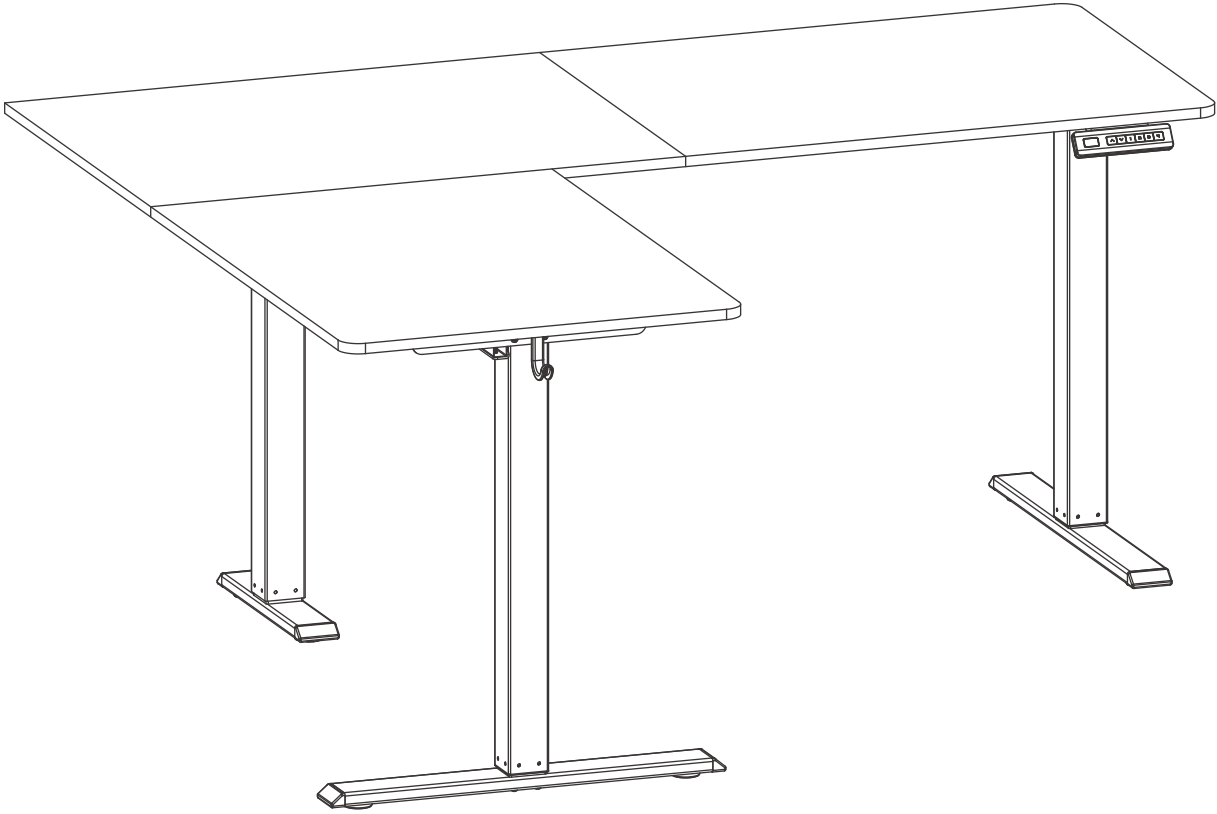

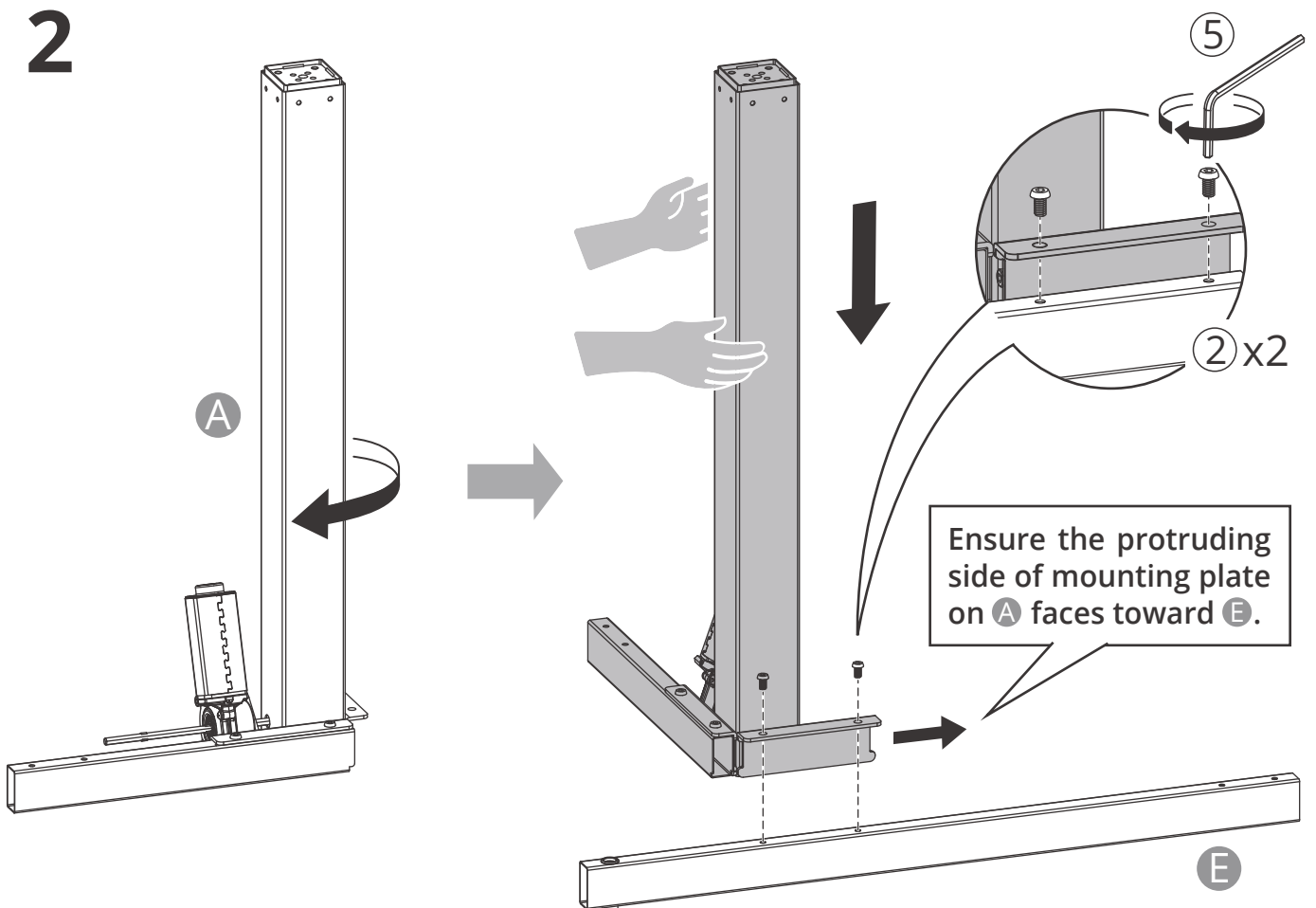
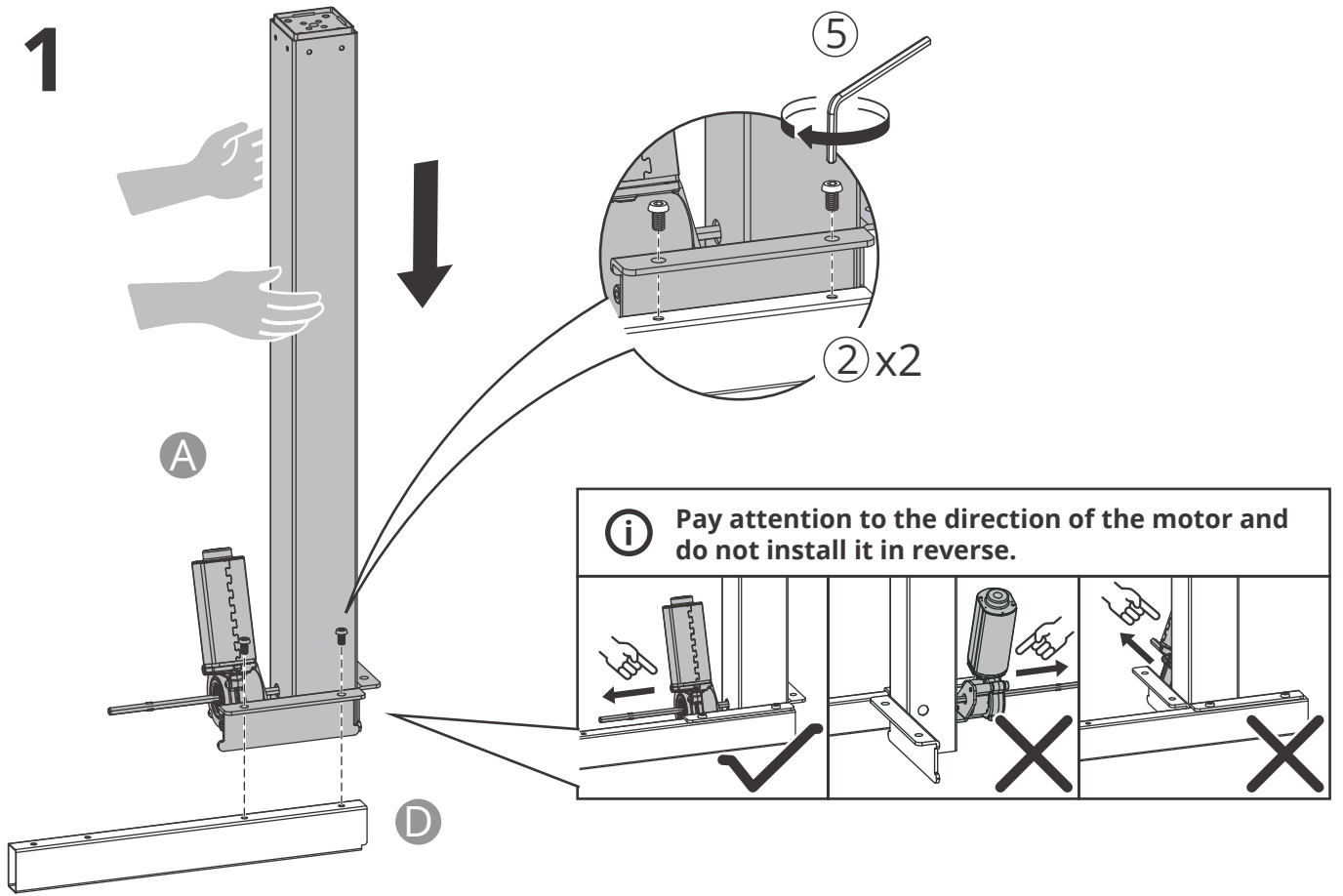

3

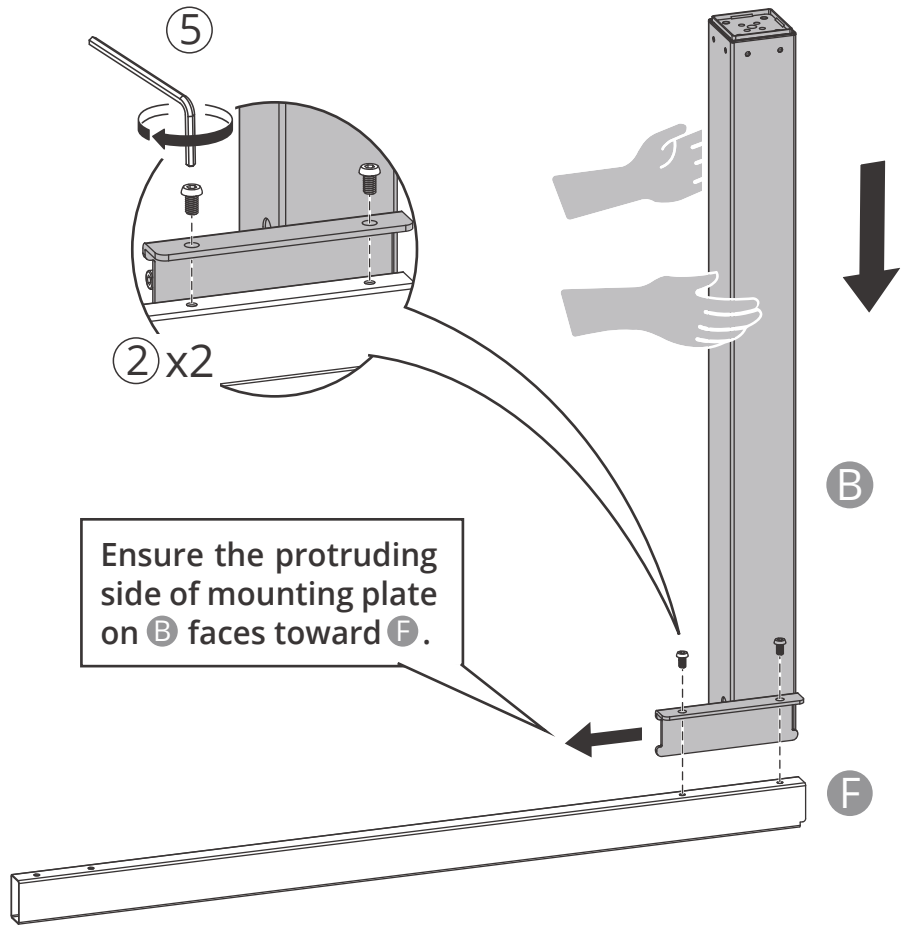

4

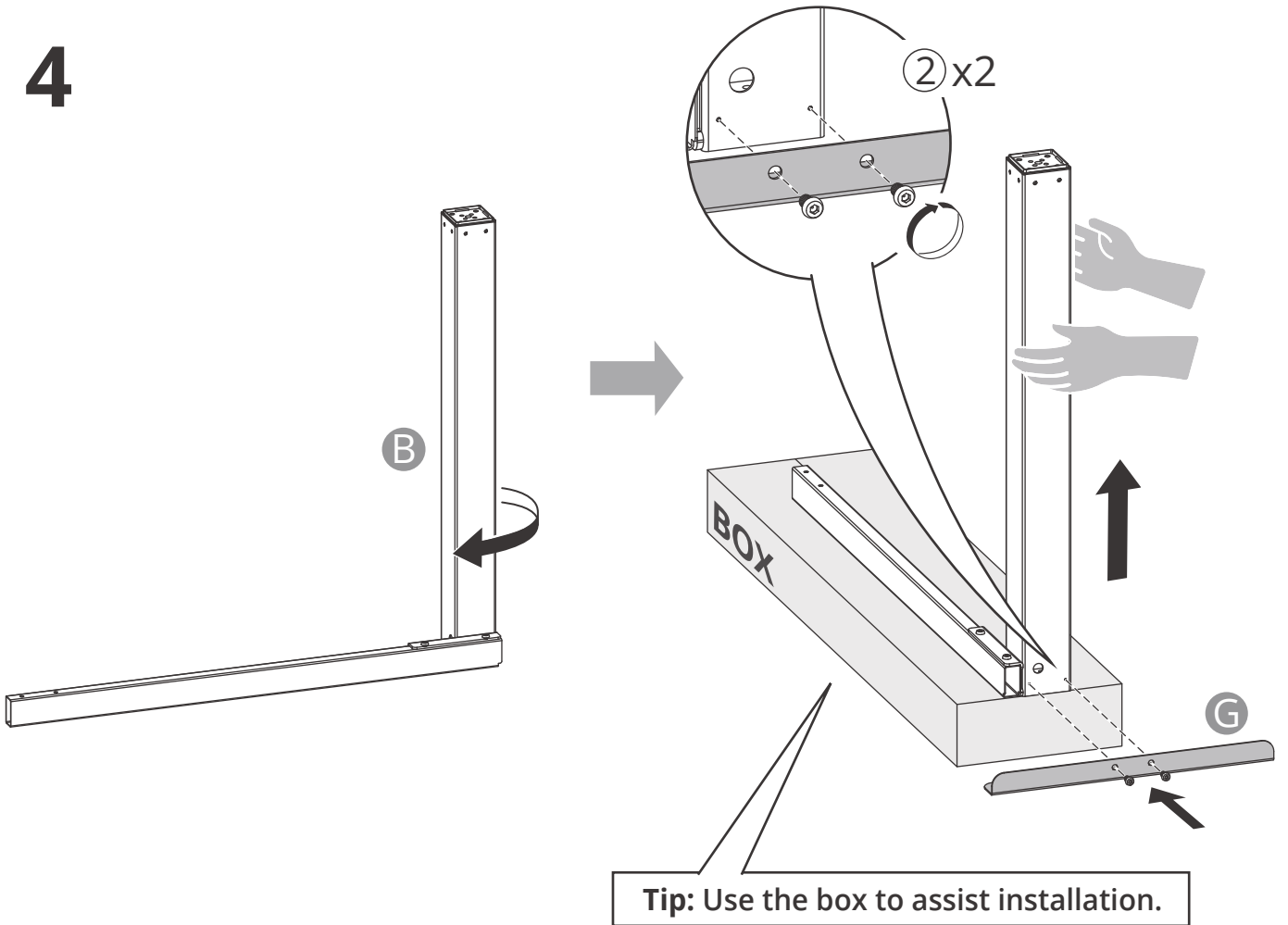

5

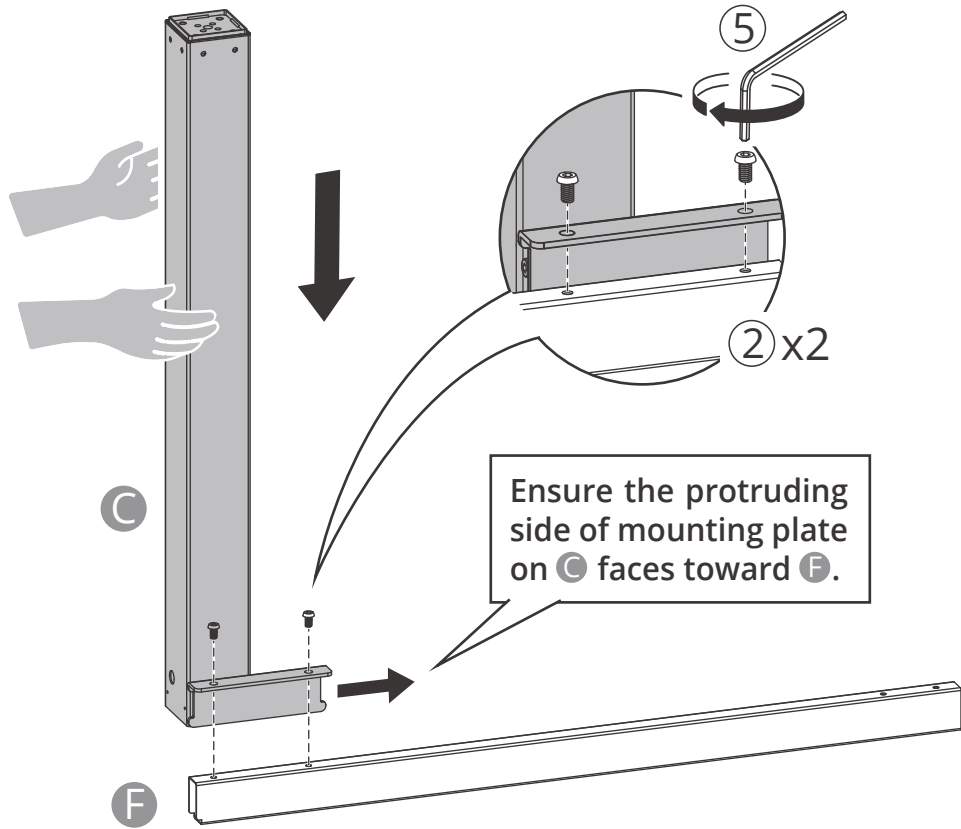

6

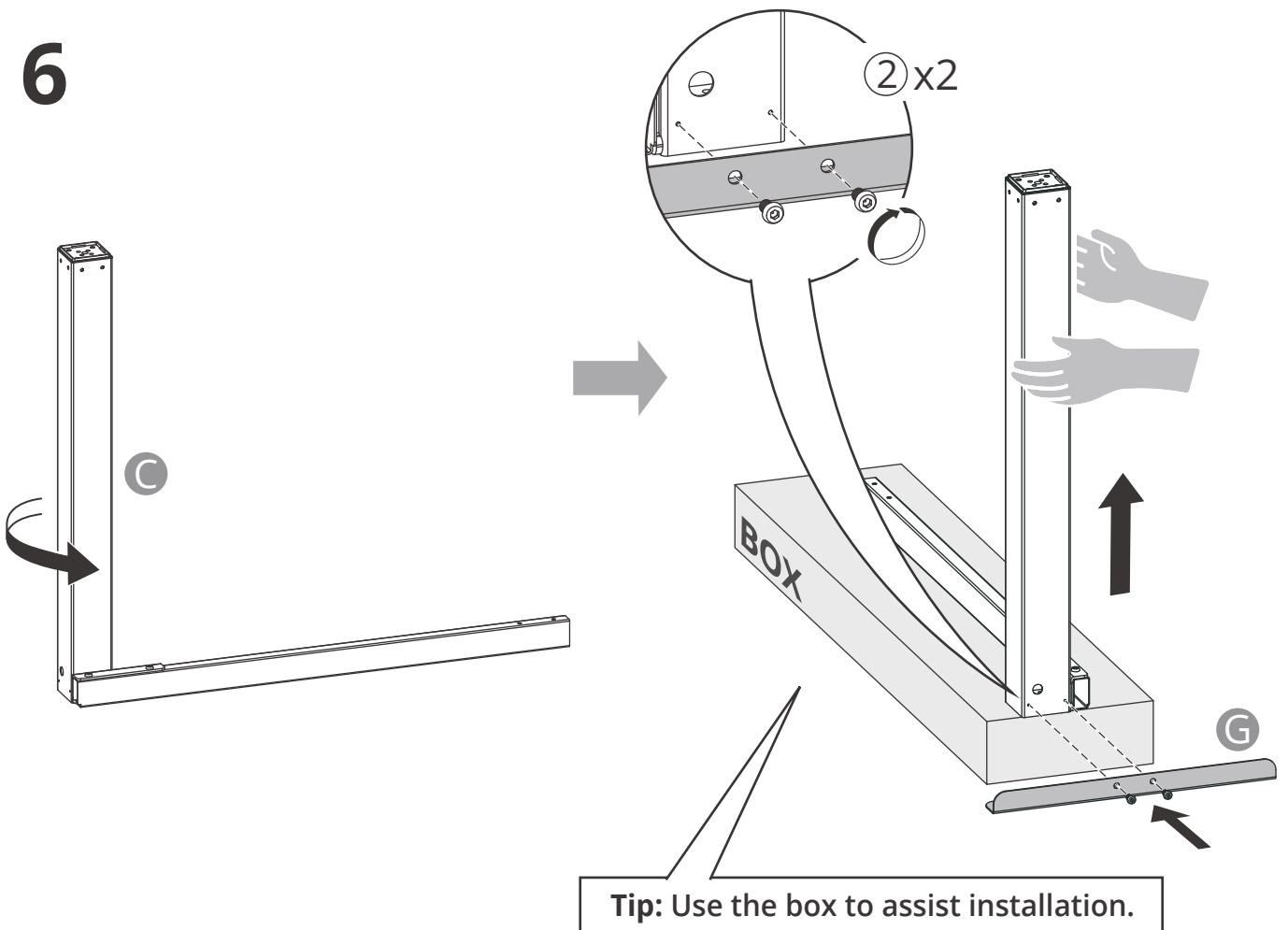

7

i Note: Direction of connectors.

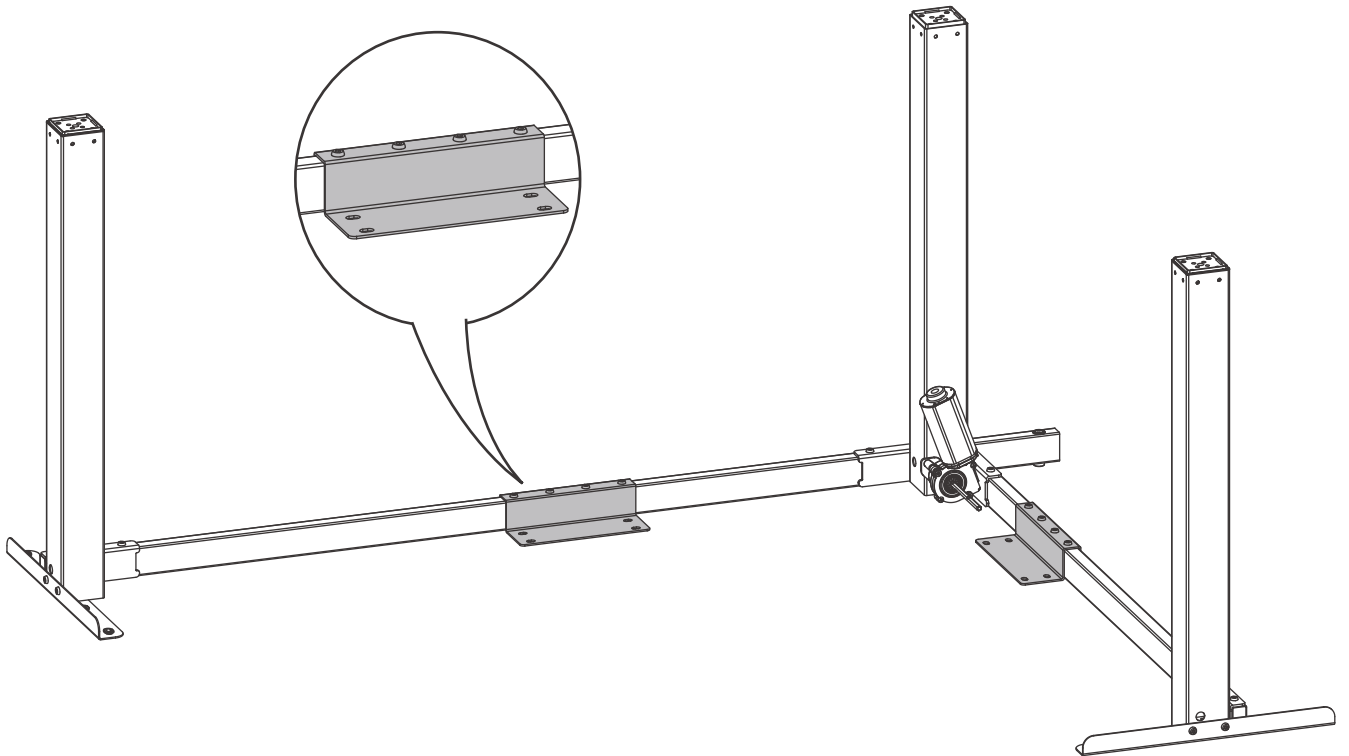
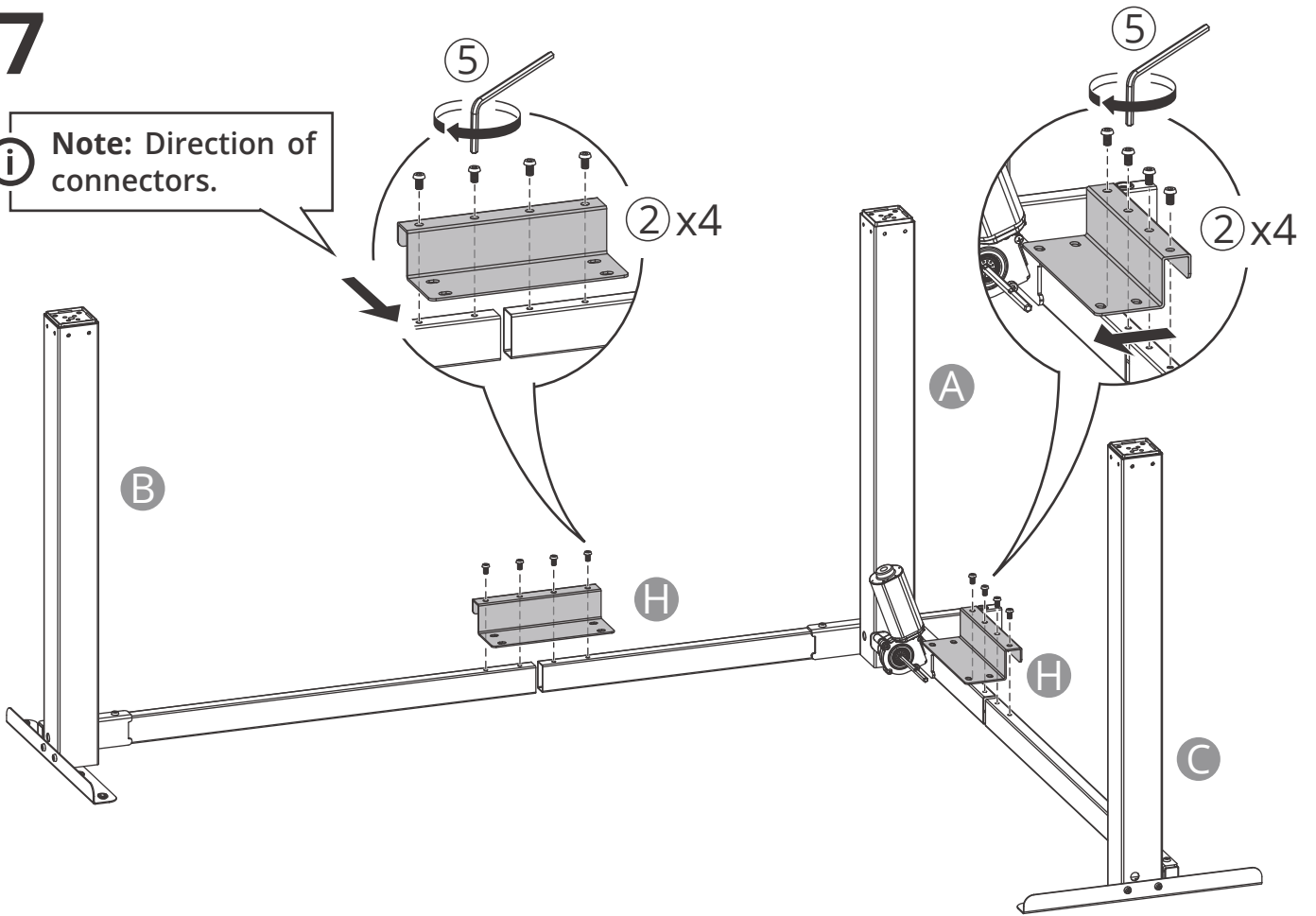

8

i Note: Please place the tabletop on the carpet for installation to prevent scratching the tabletop.

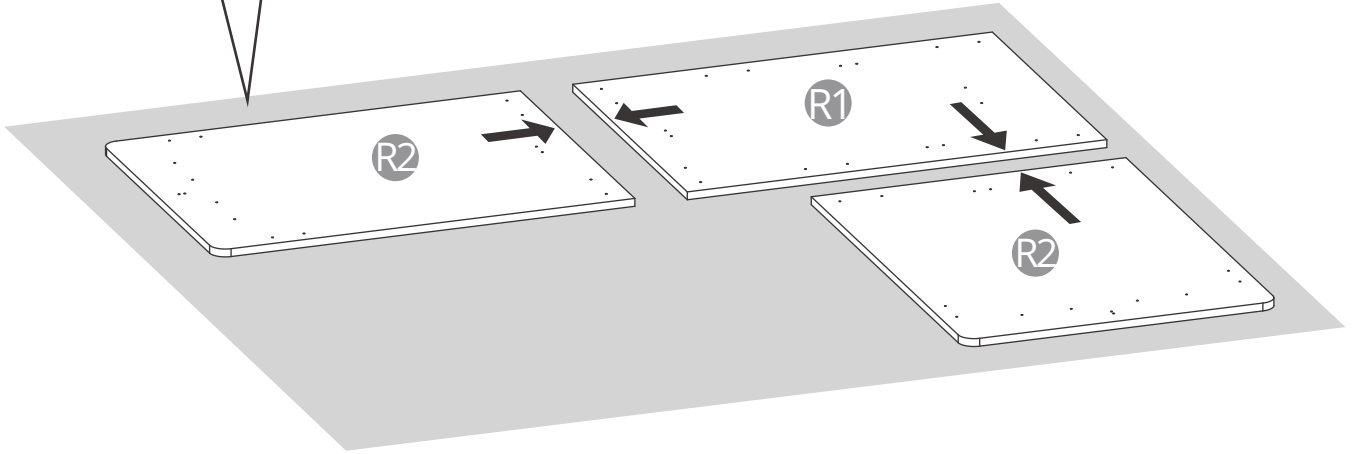

9

i Note: Please tighten screws gently to 4-5 N.m. Do not overtighten.

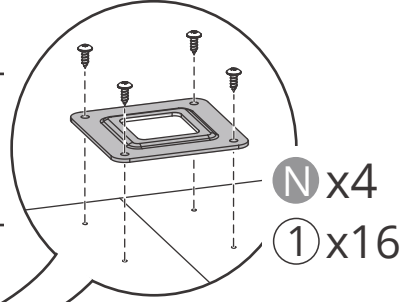

Join firmly together

Join firmly together

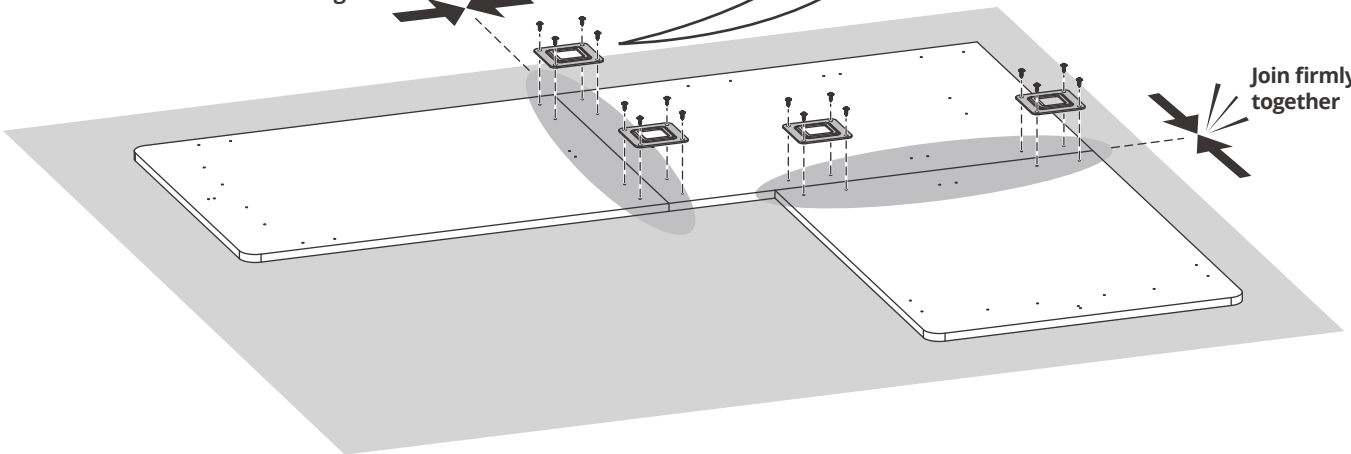

10

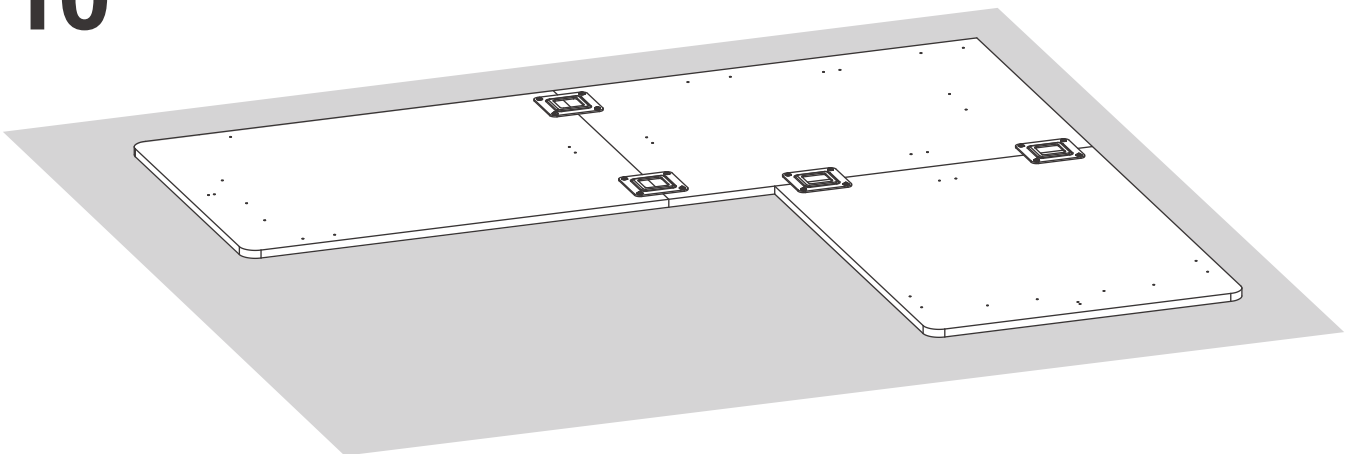

11

i Note: Enjoy the freedom to mount the hand set on either left / right side beneath the desktop.

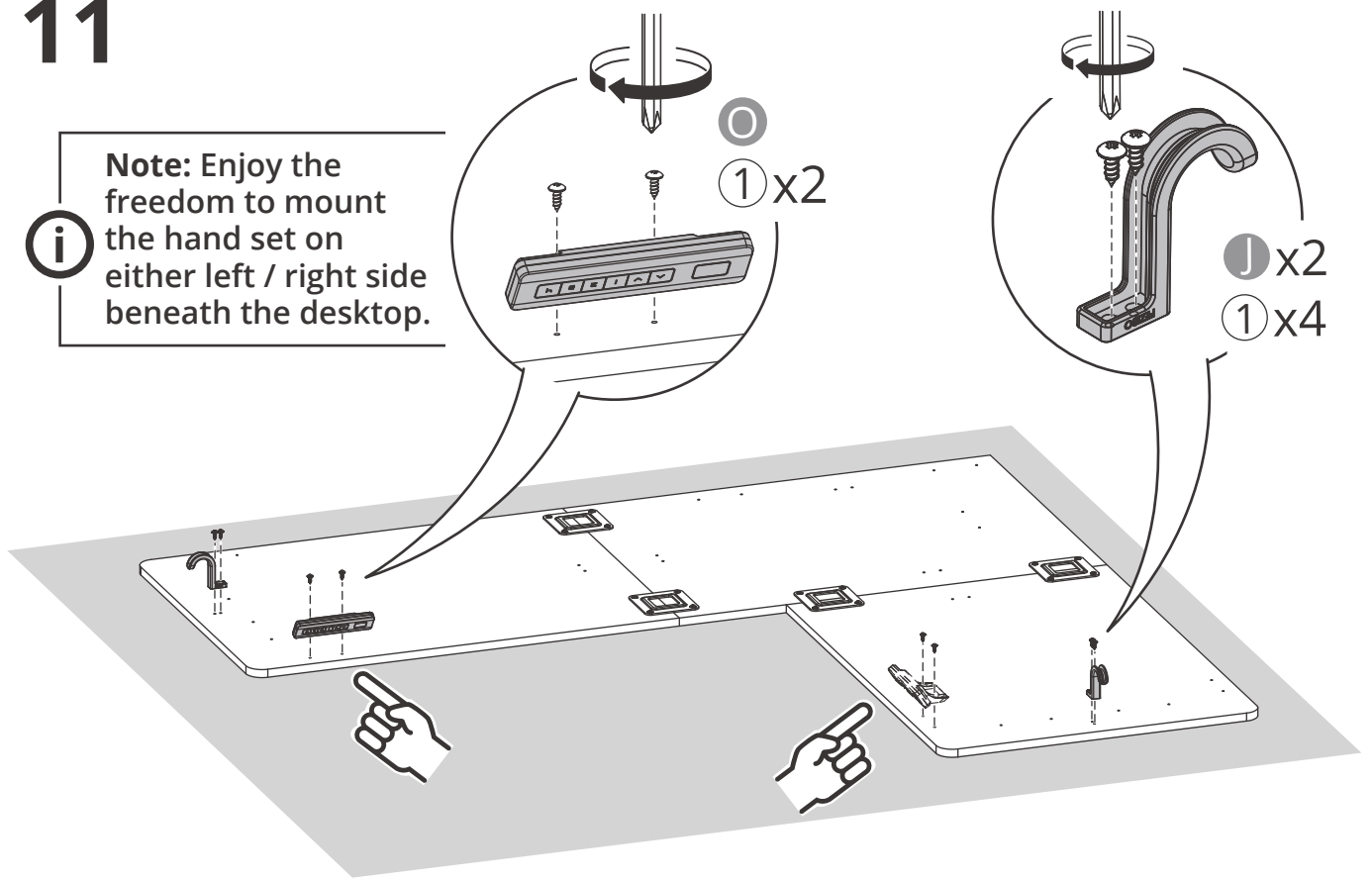

12

i Ensure all holes are aligned before tightening the screws.

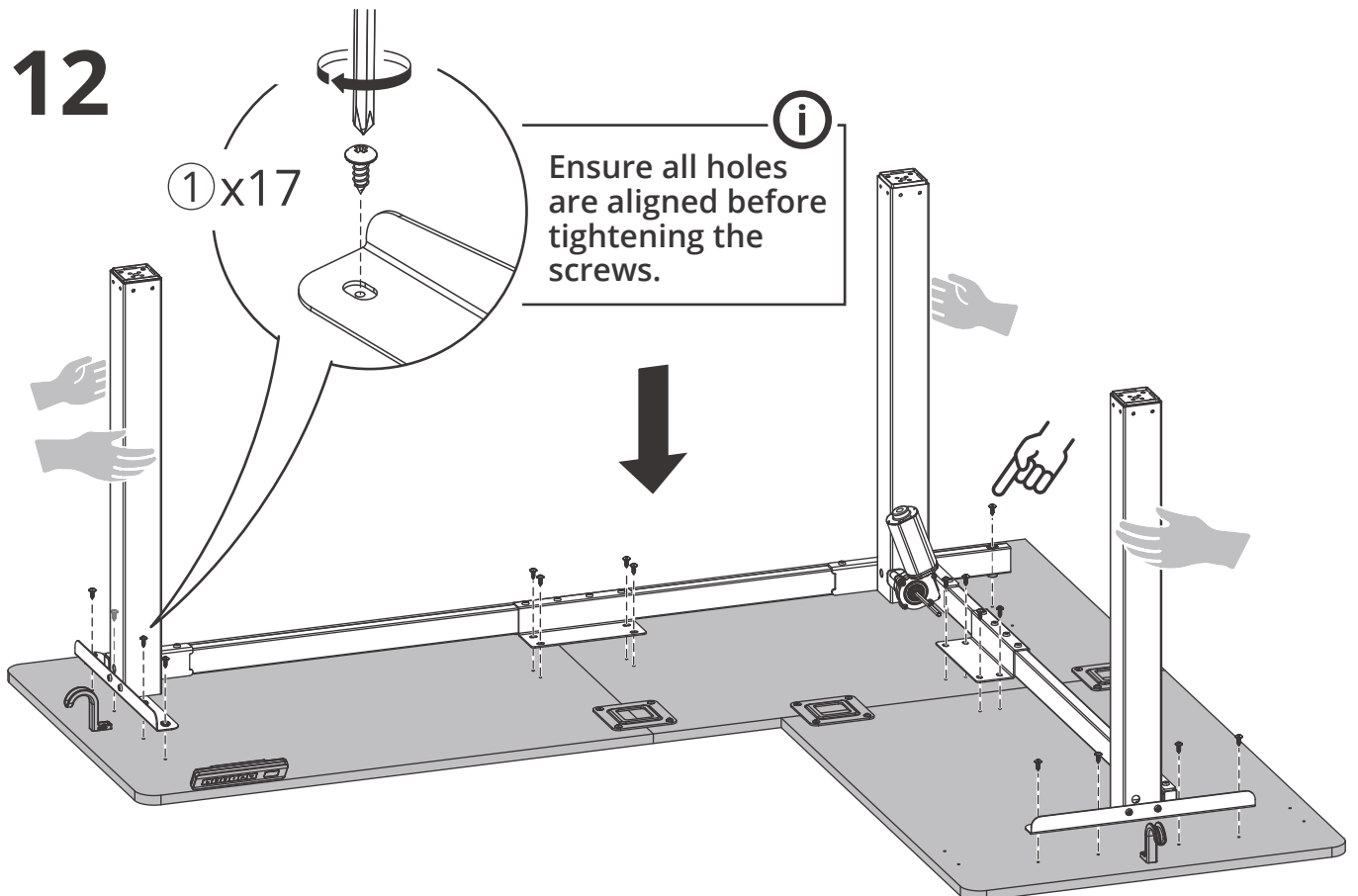

13

i Note: Align and fully insert the hexagonal sync rod until the locking point engages to avoid uneven height adjustment.

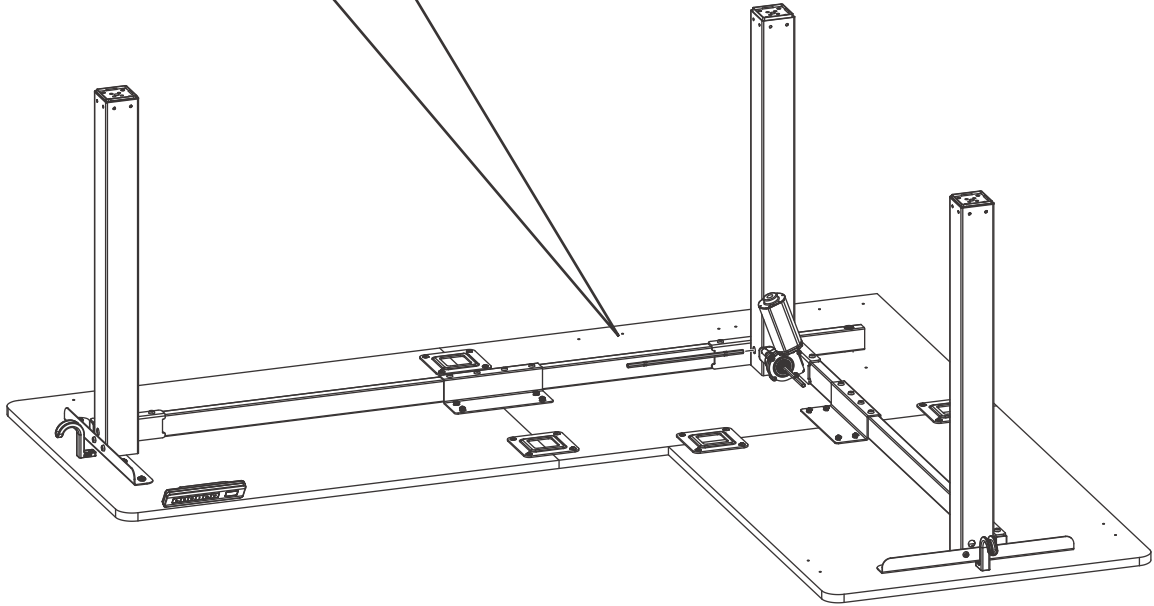
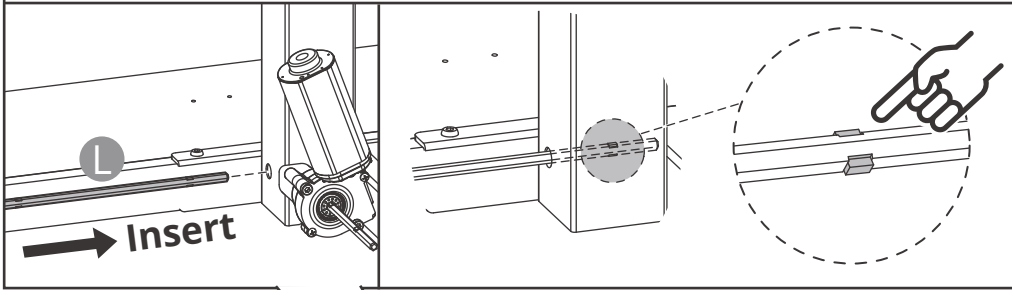

14

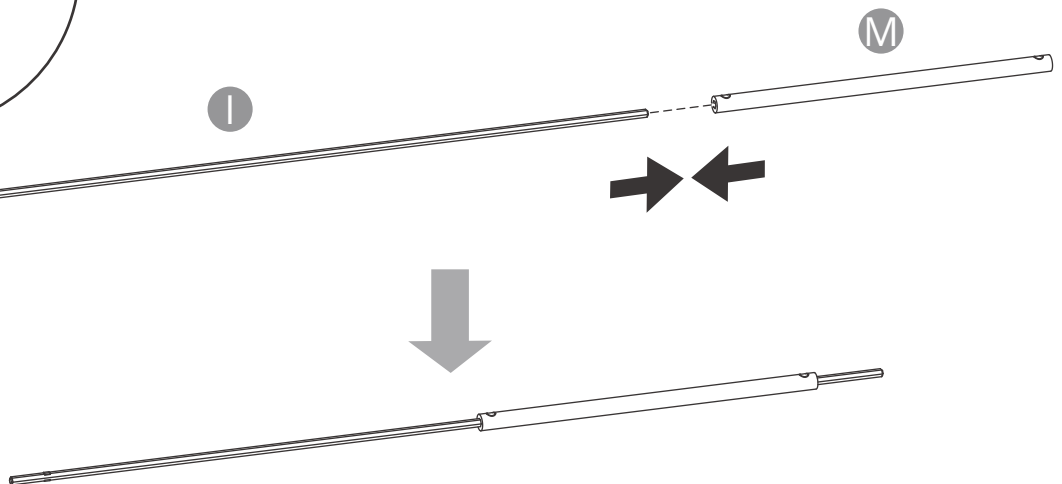
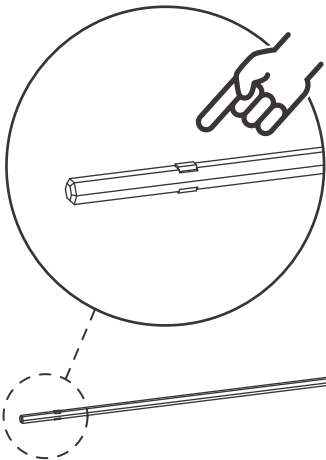

15

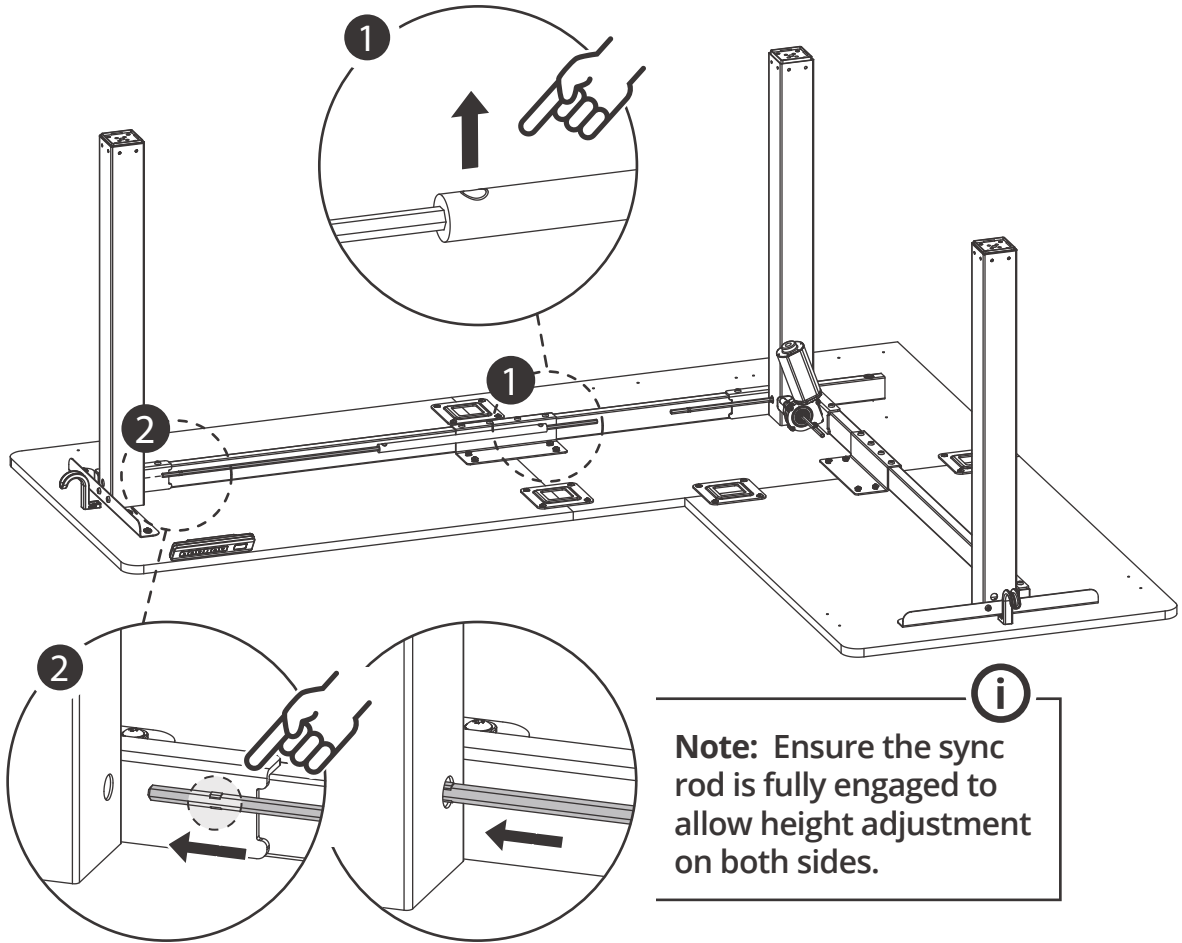

16

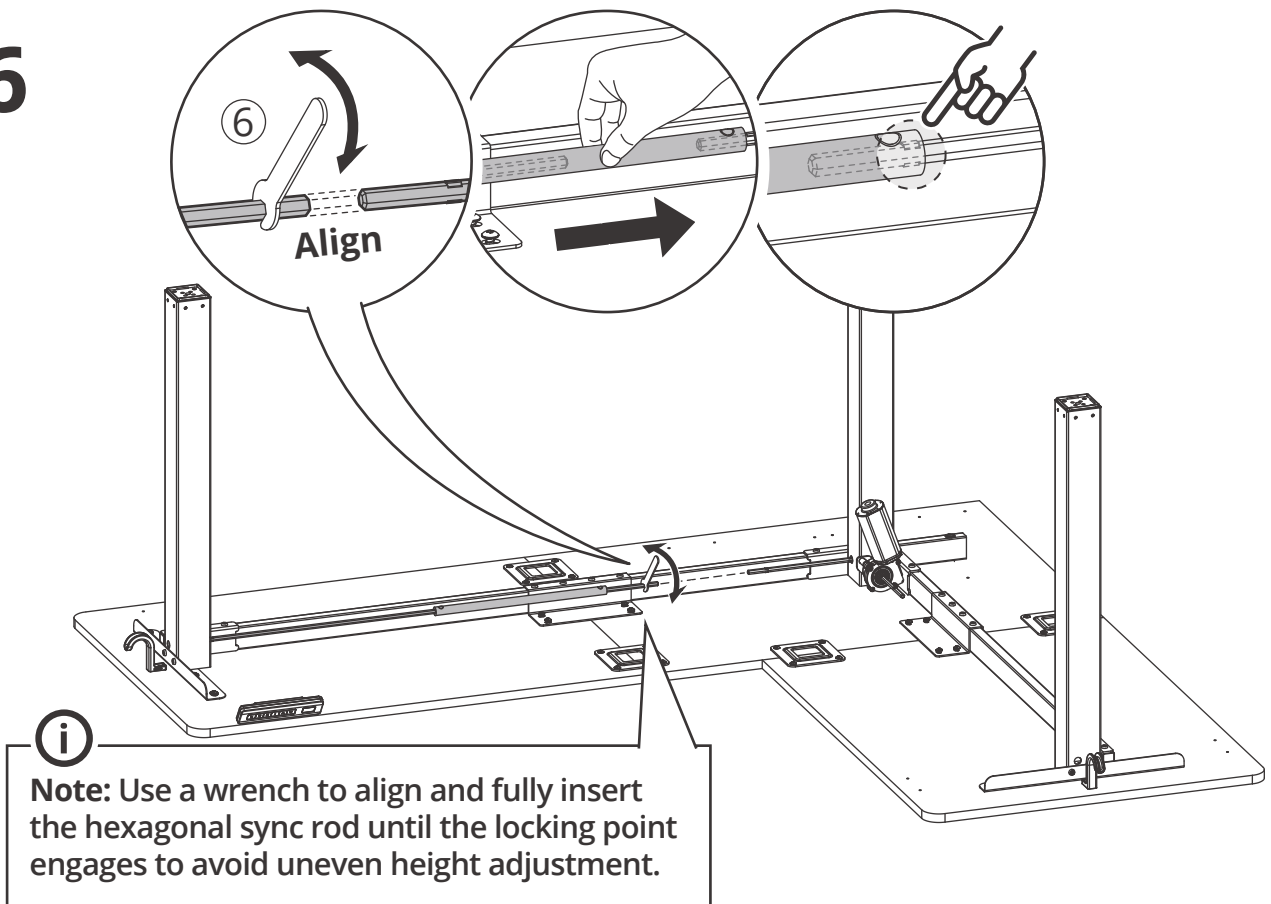

17

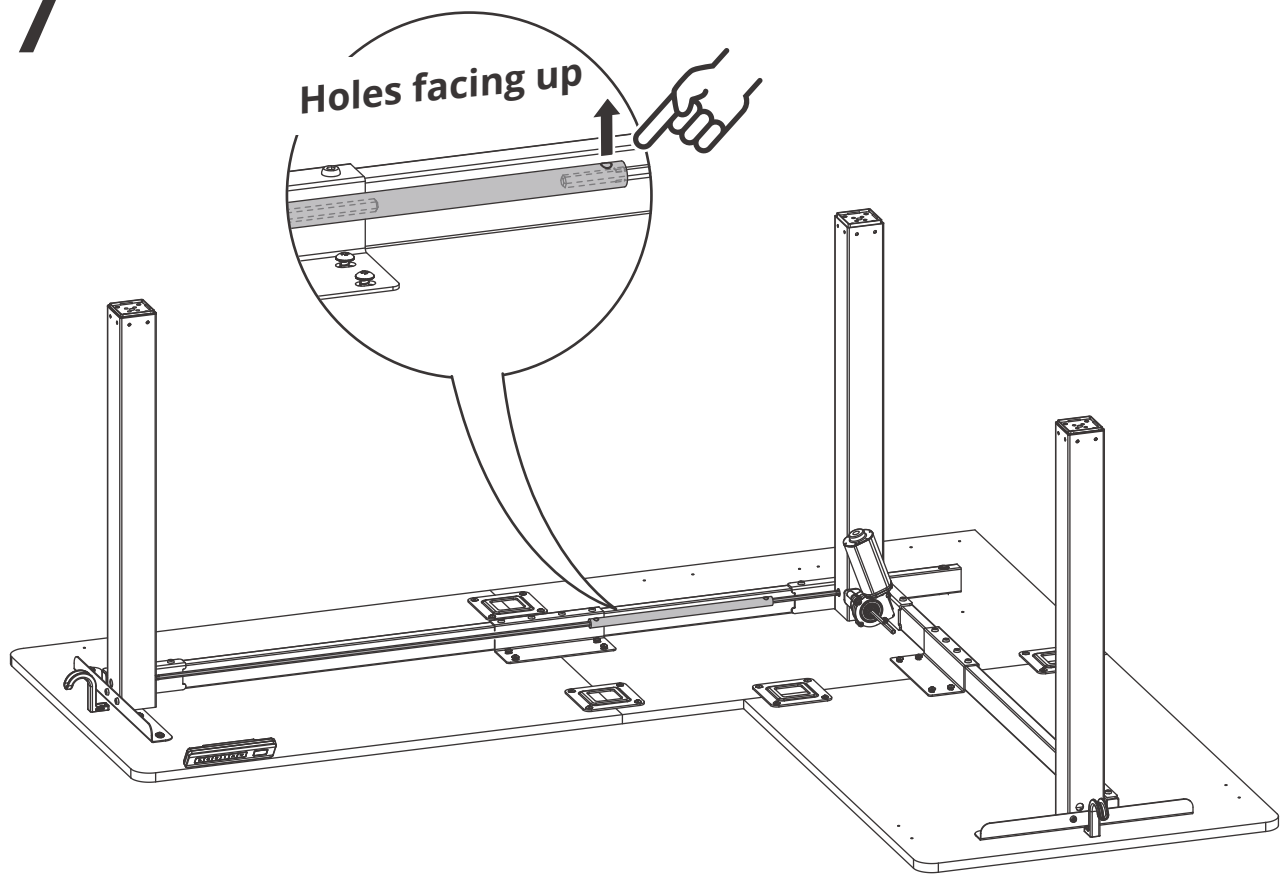

18

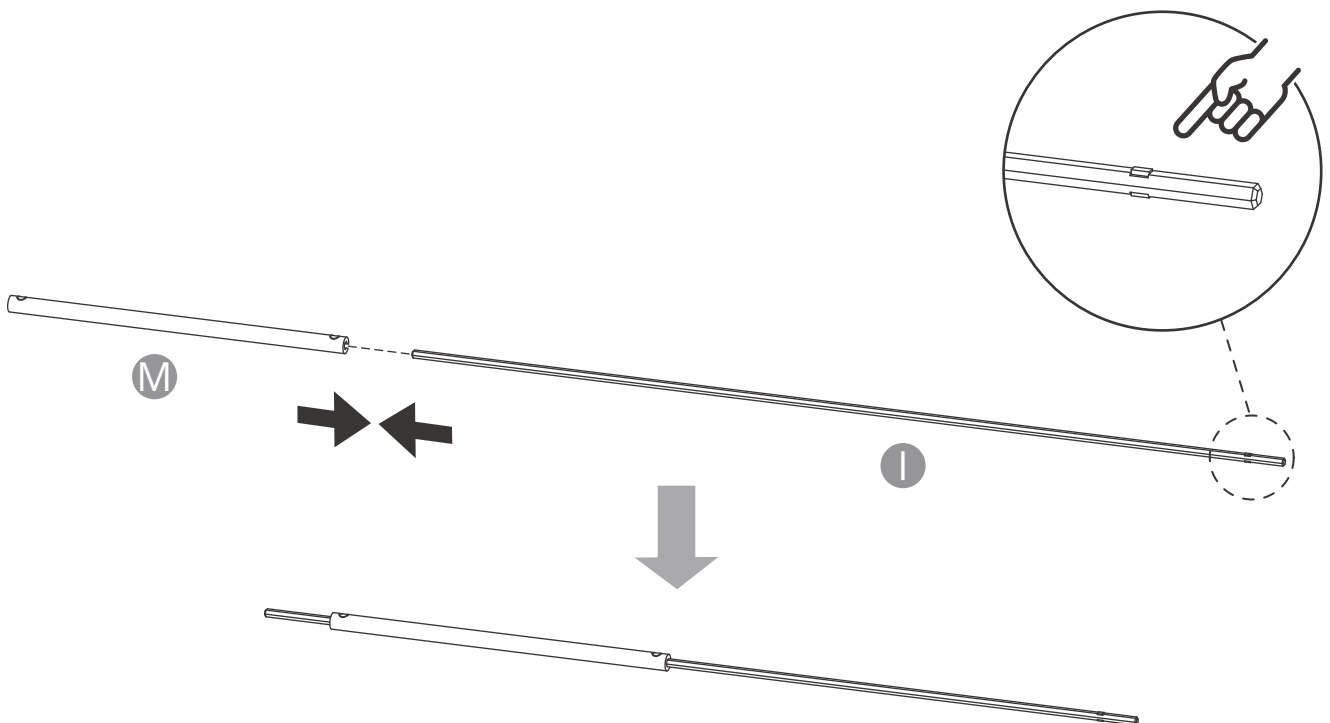

19

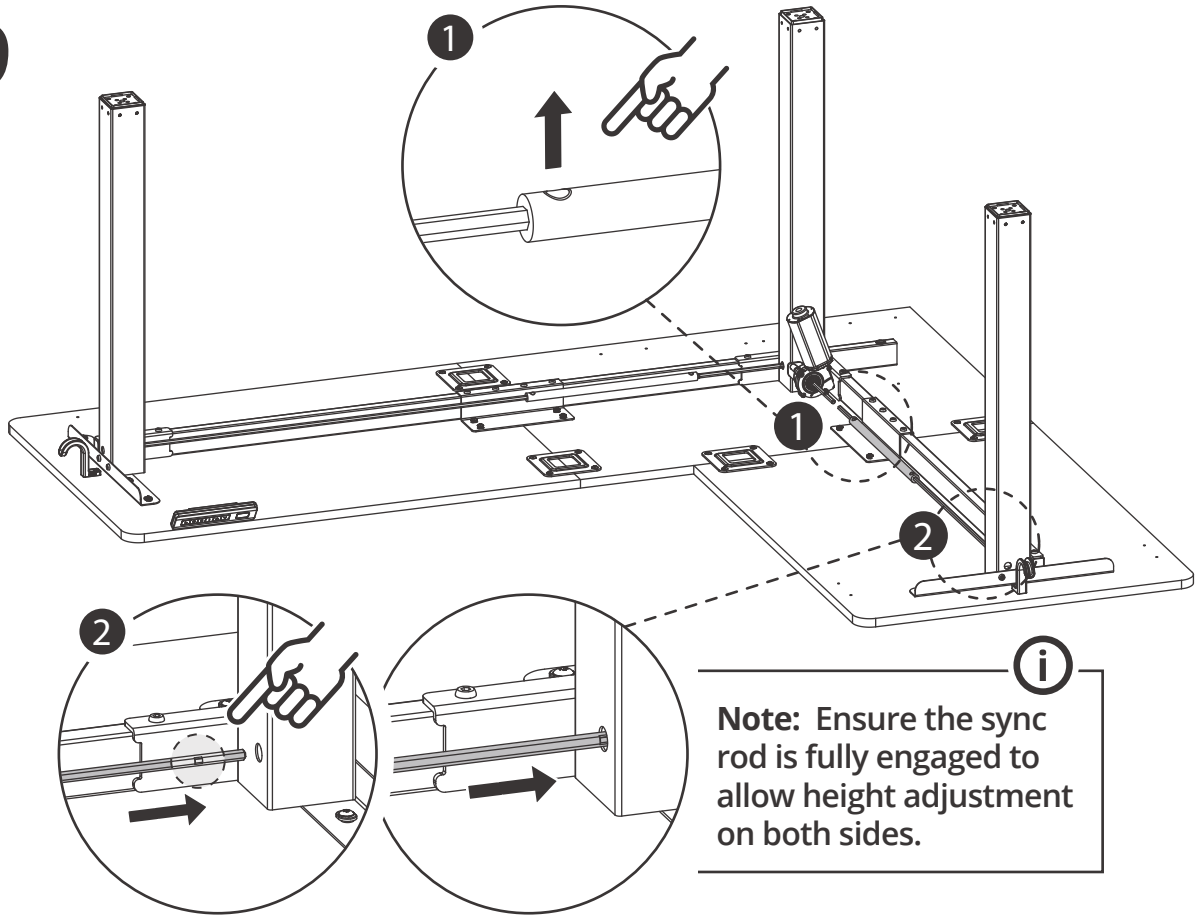

20

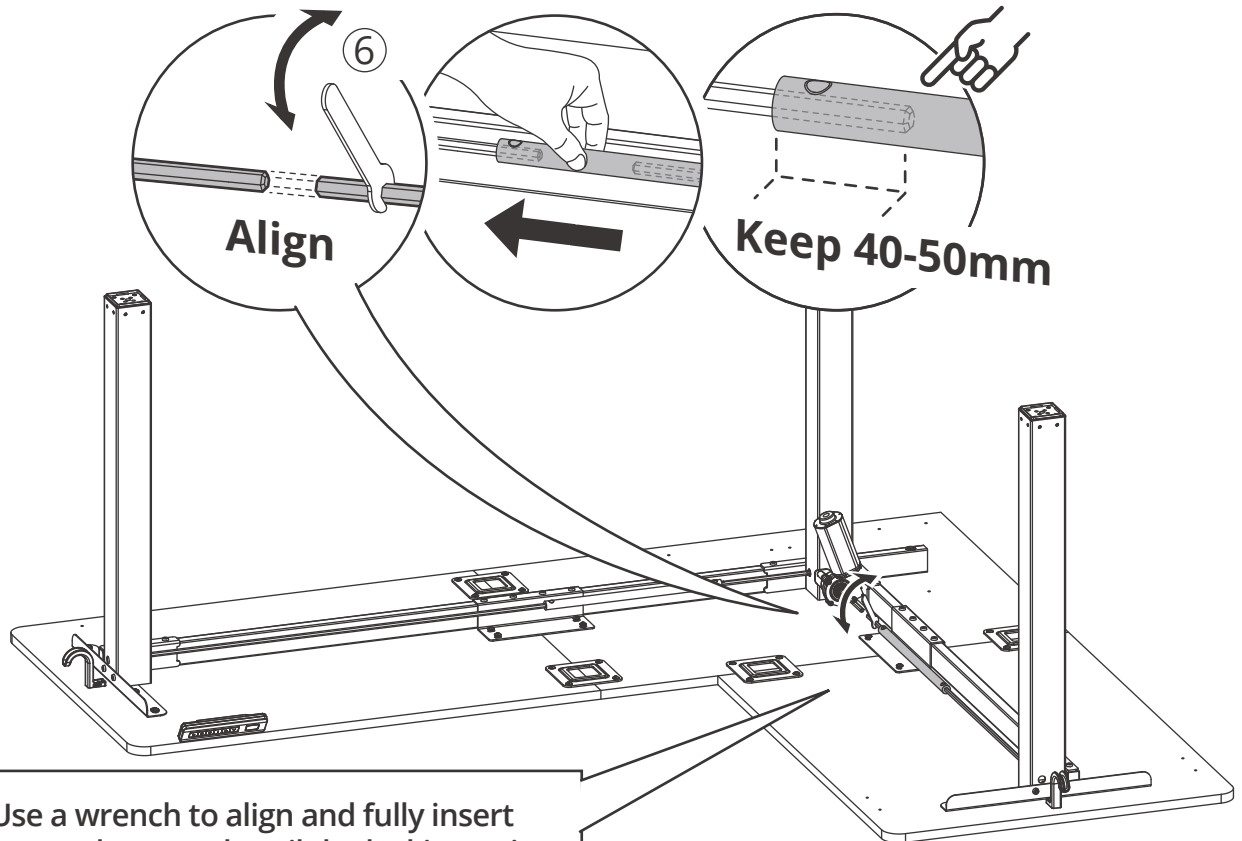

21

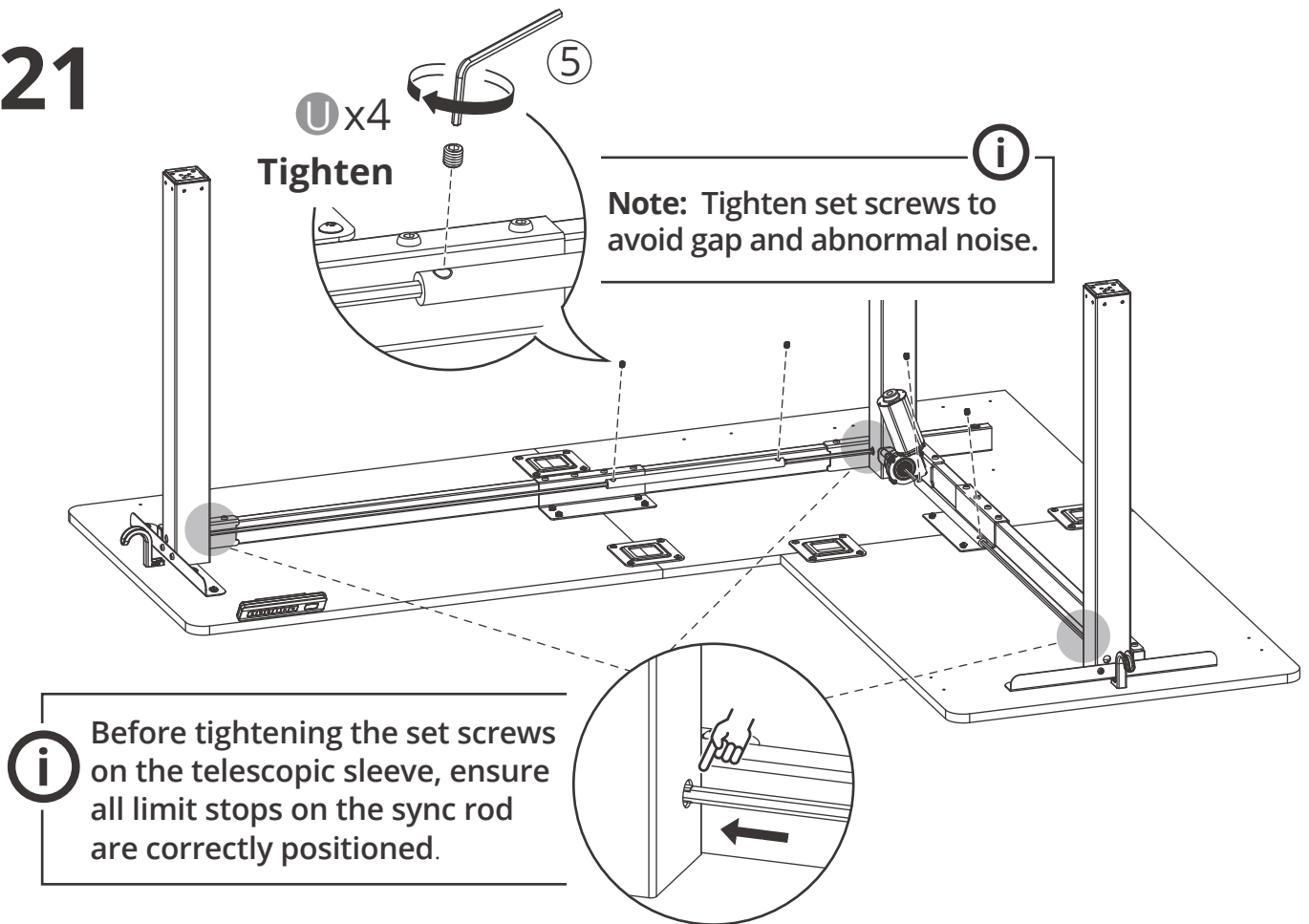

22

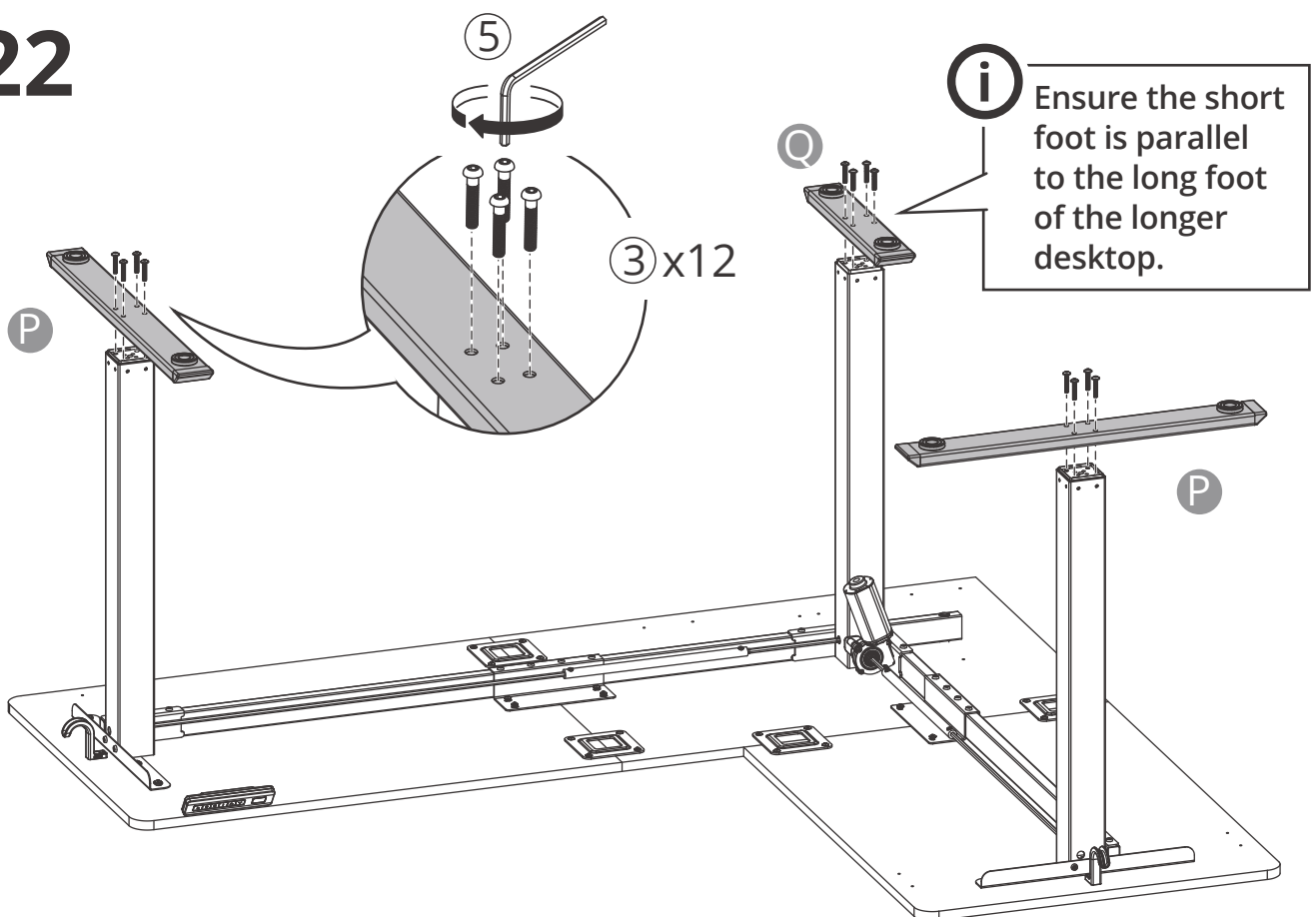

23

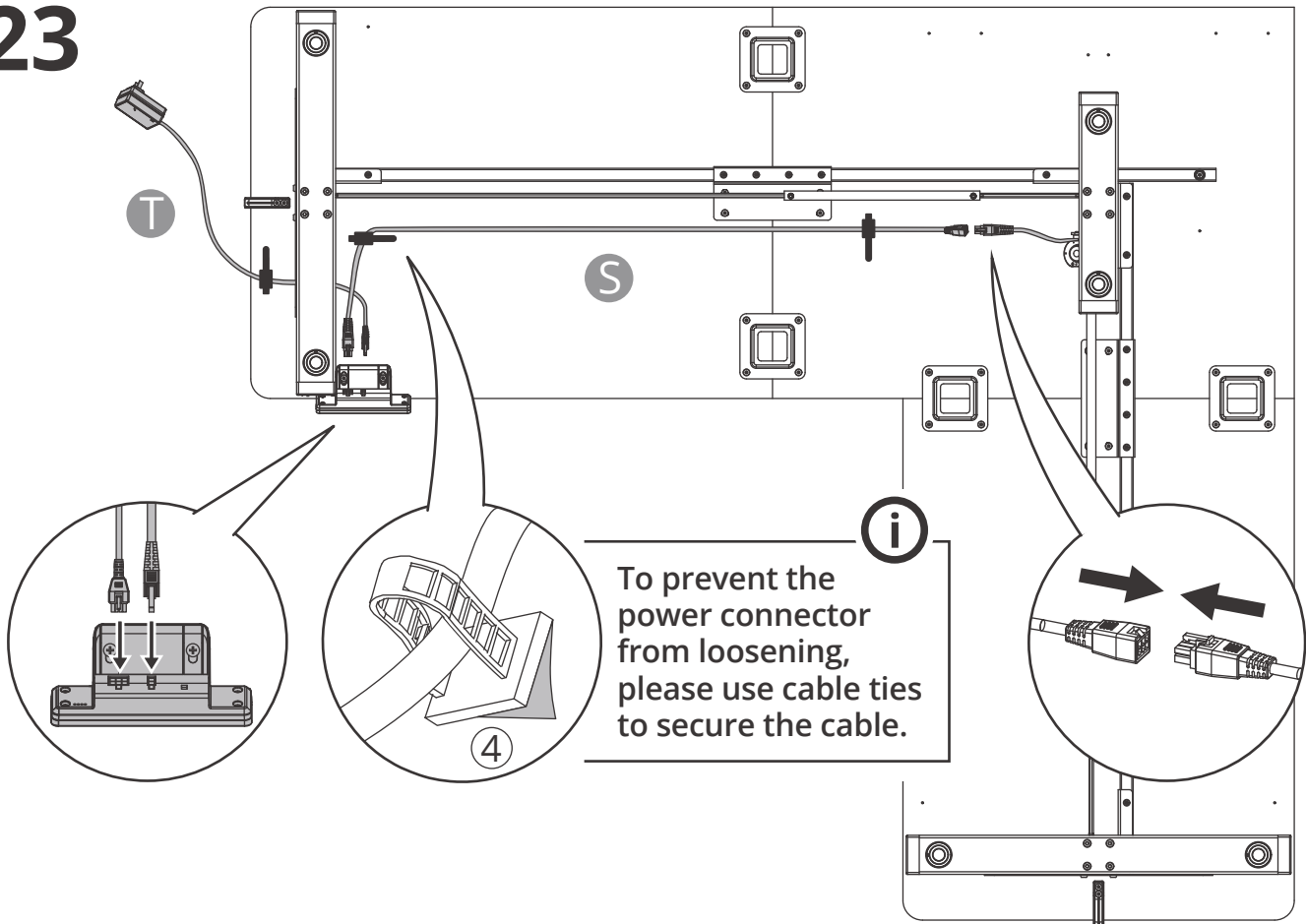

To prevent the power connector from loosening, please use cable ties to secure the cable.

24

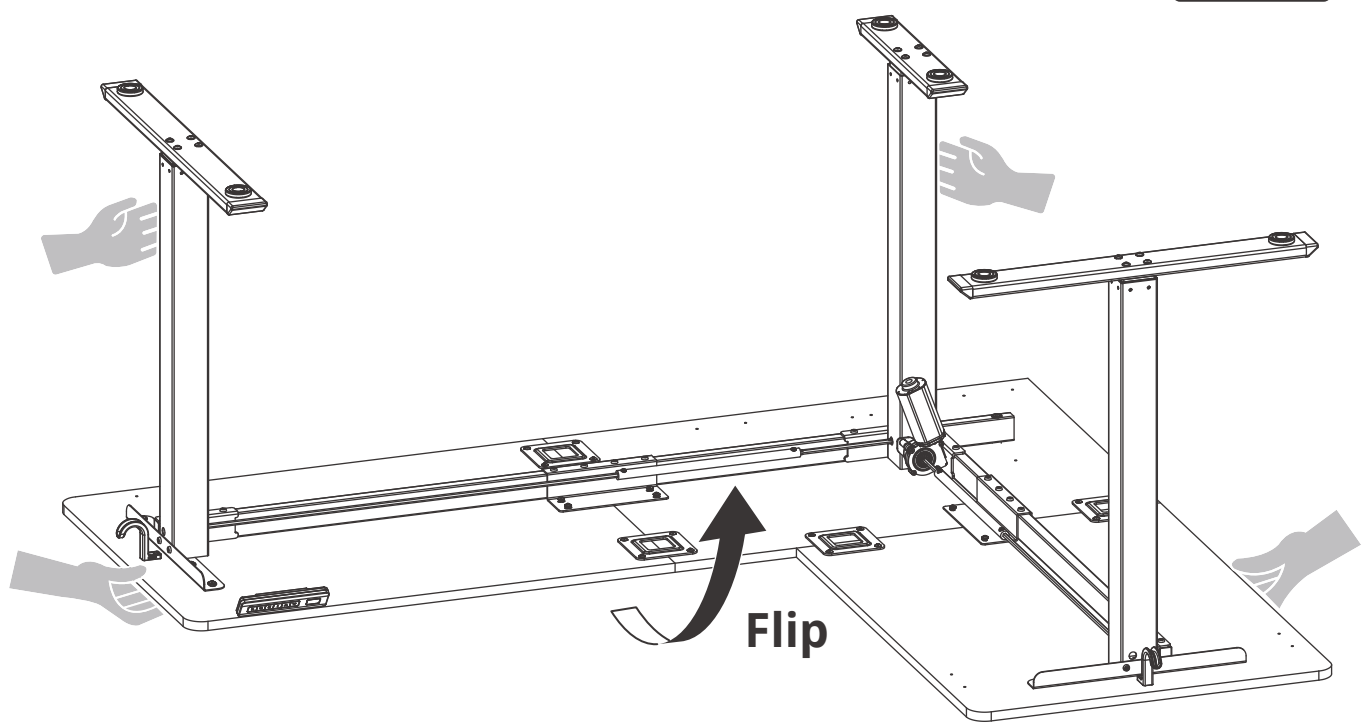



Option 2

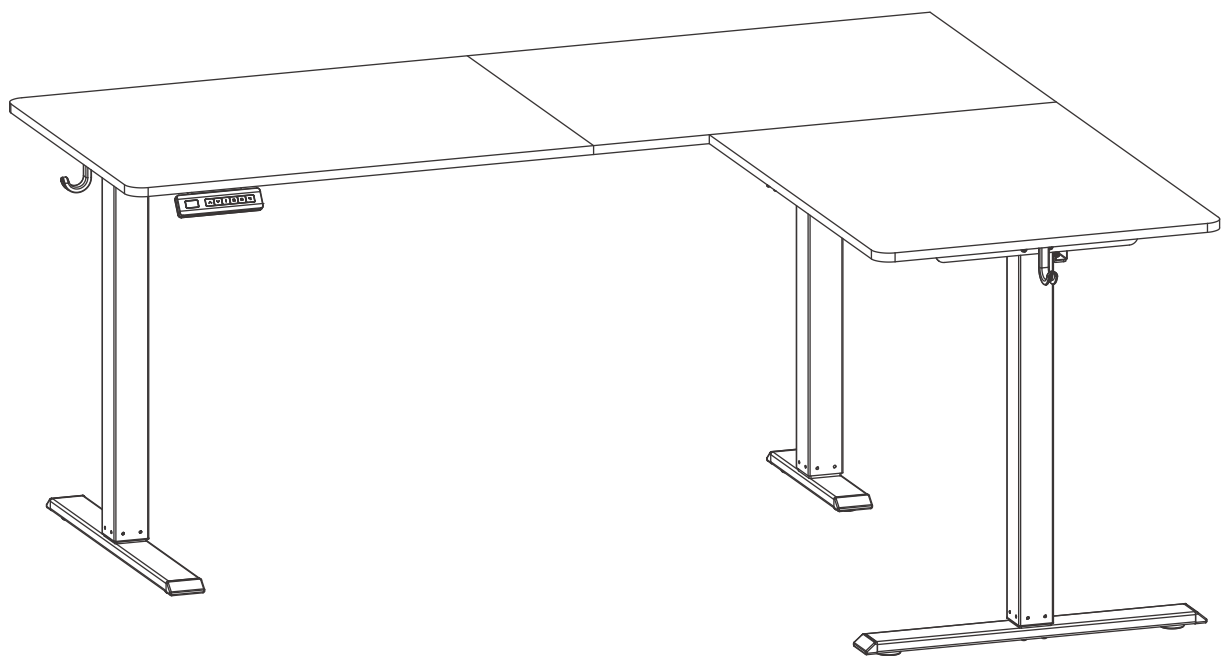

Page 20-33

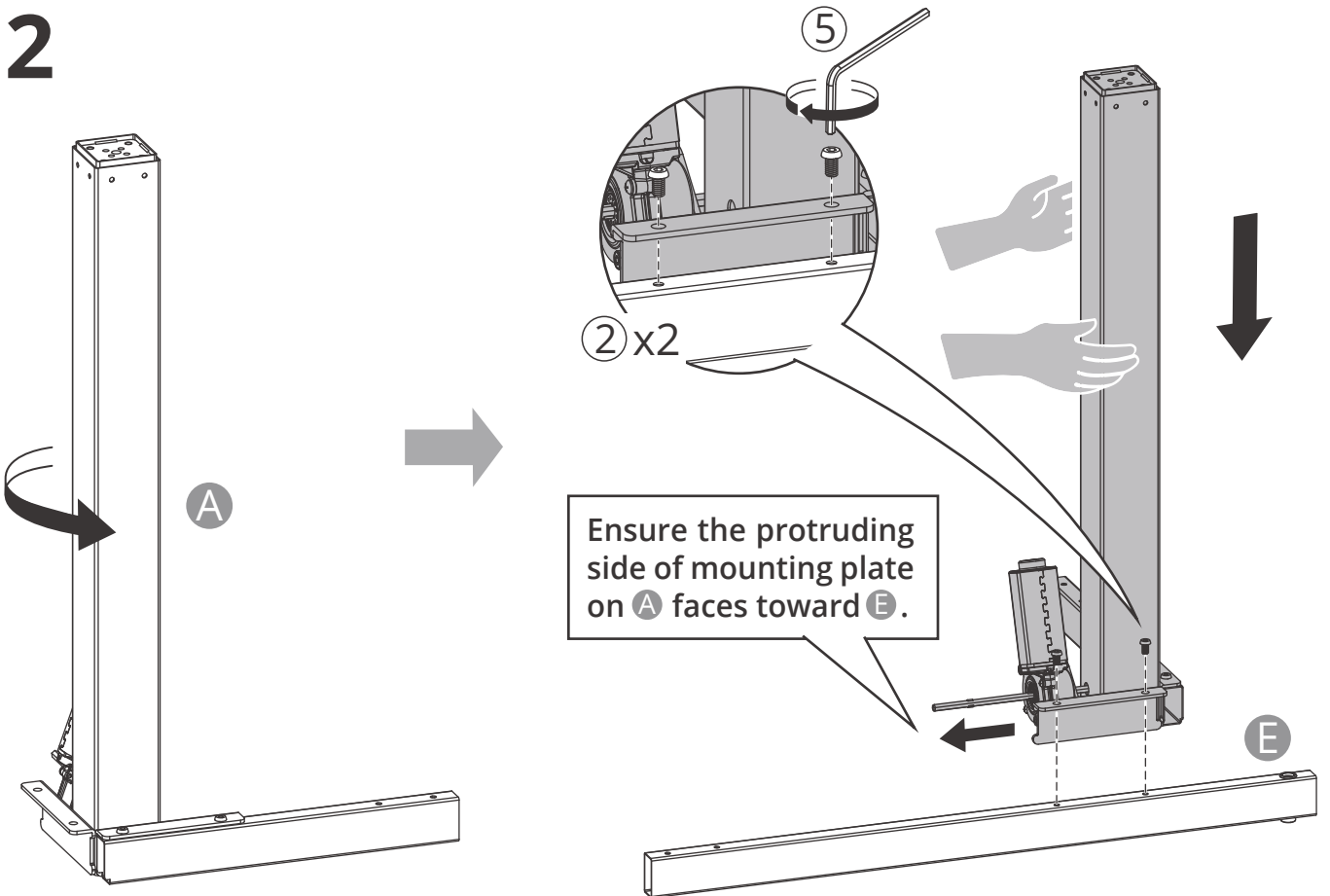
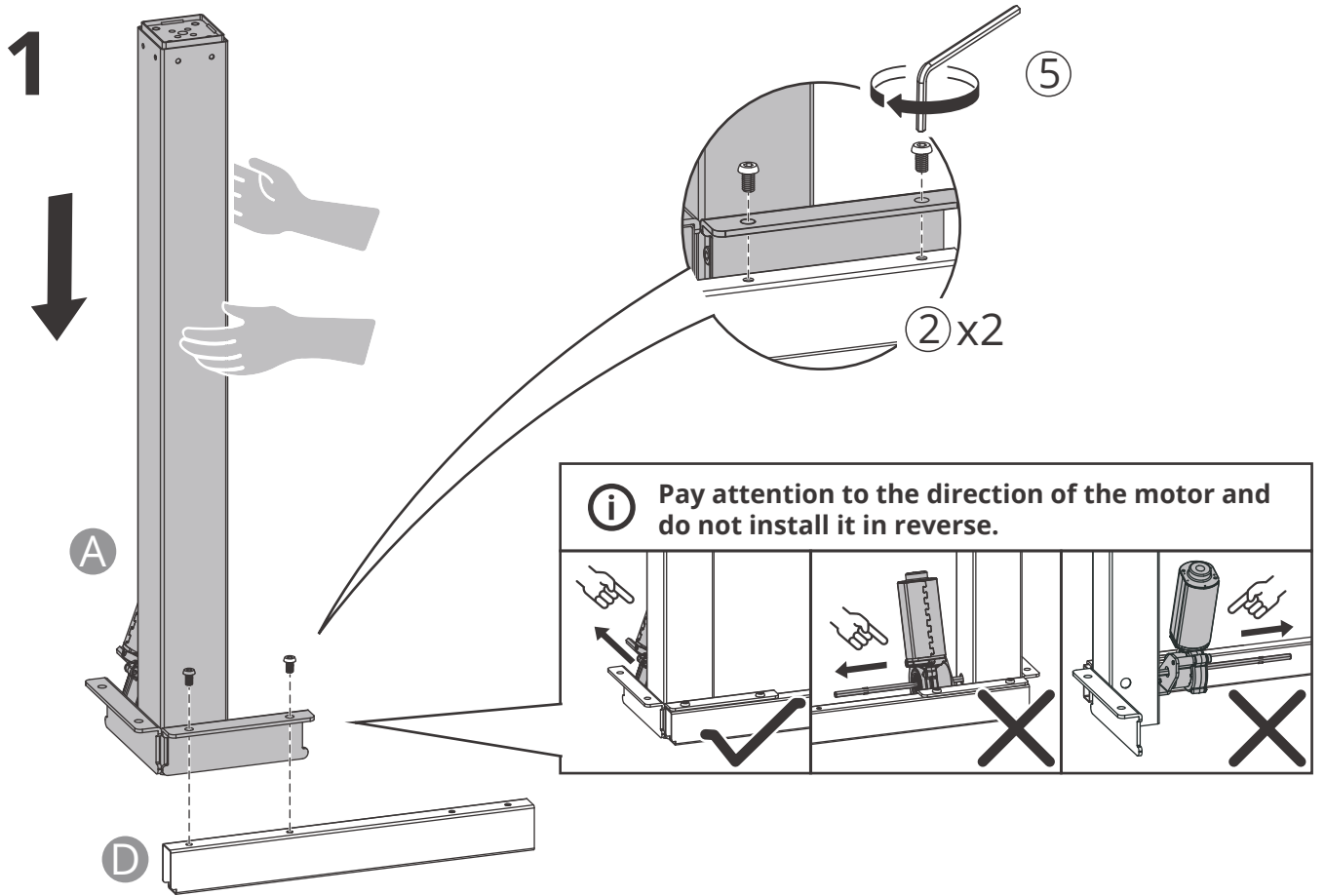

3

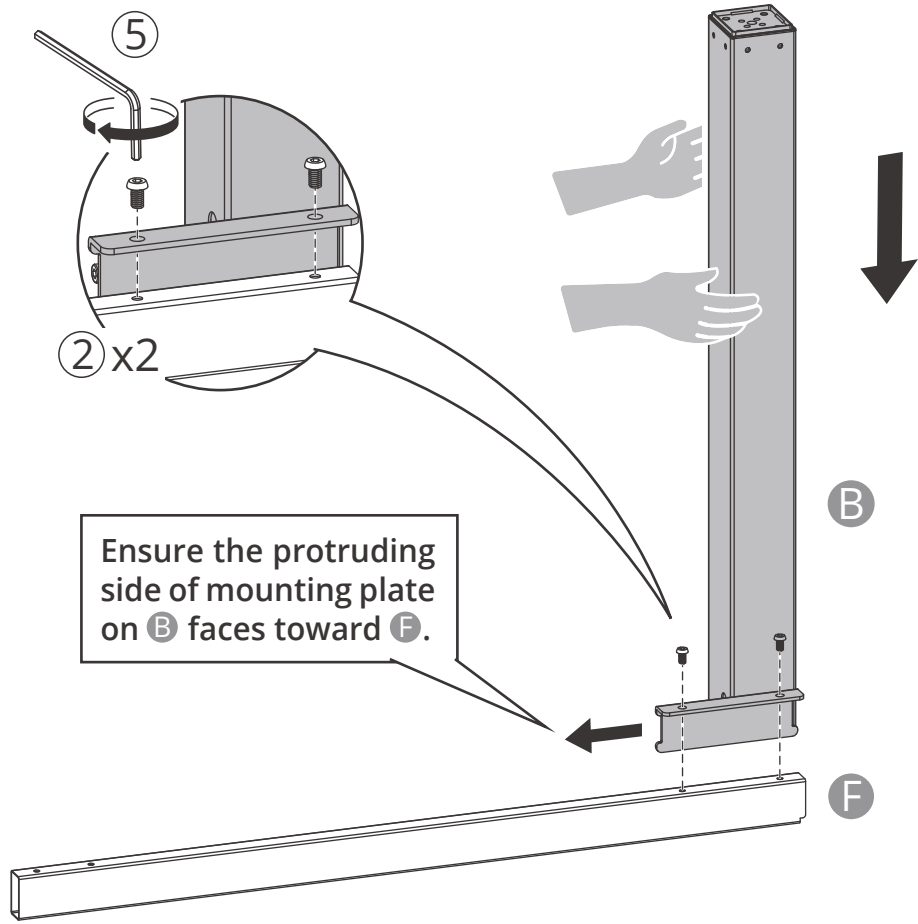

4

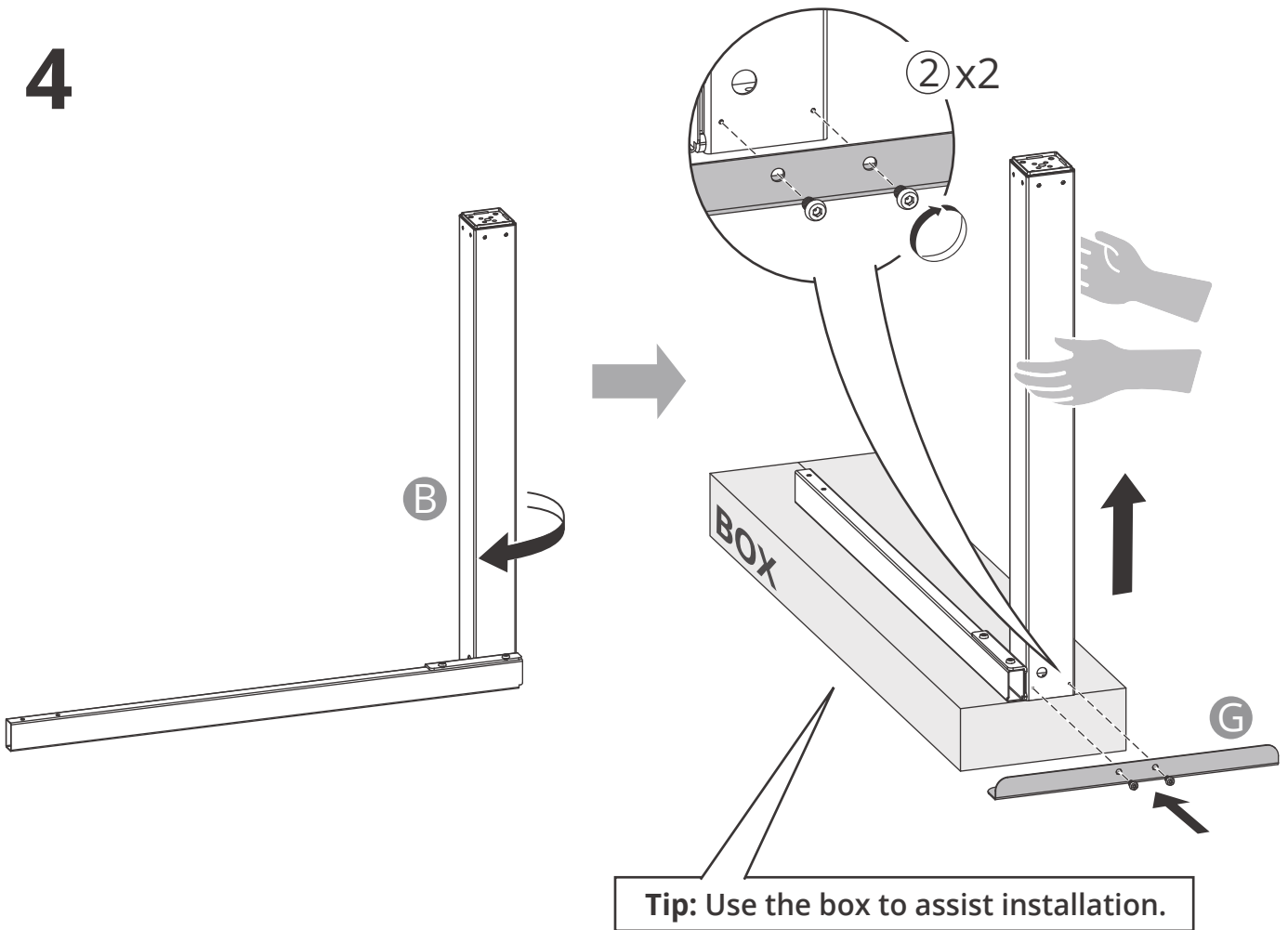

5

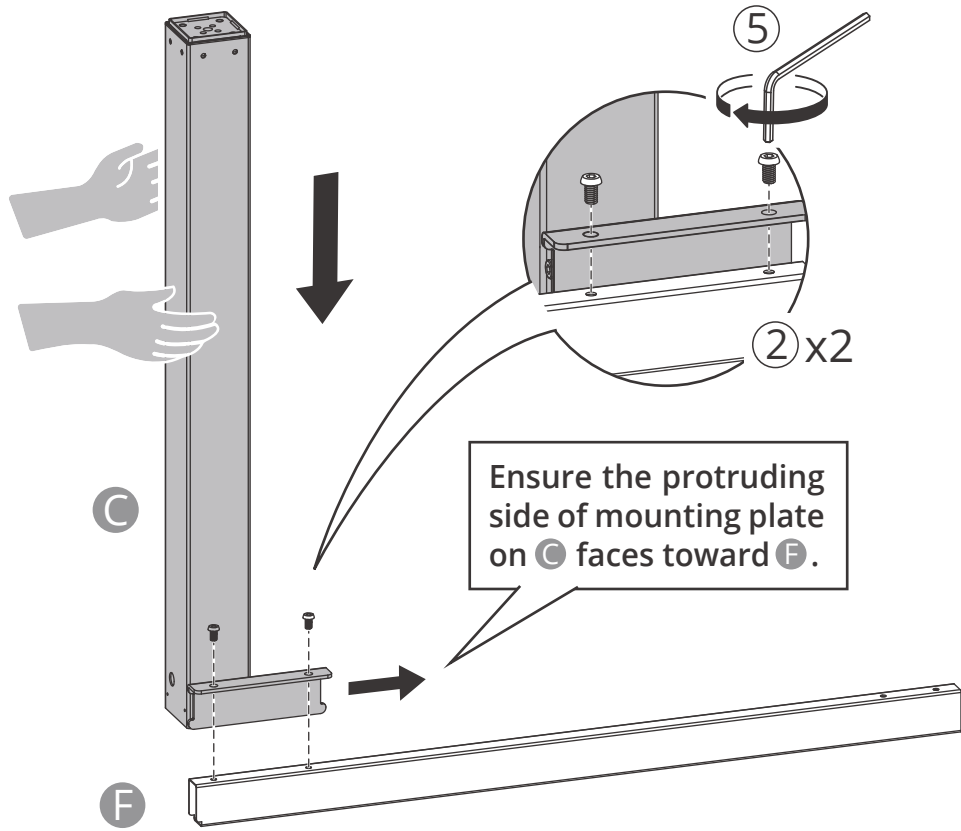

6

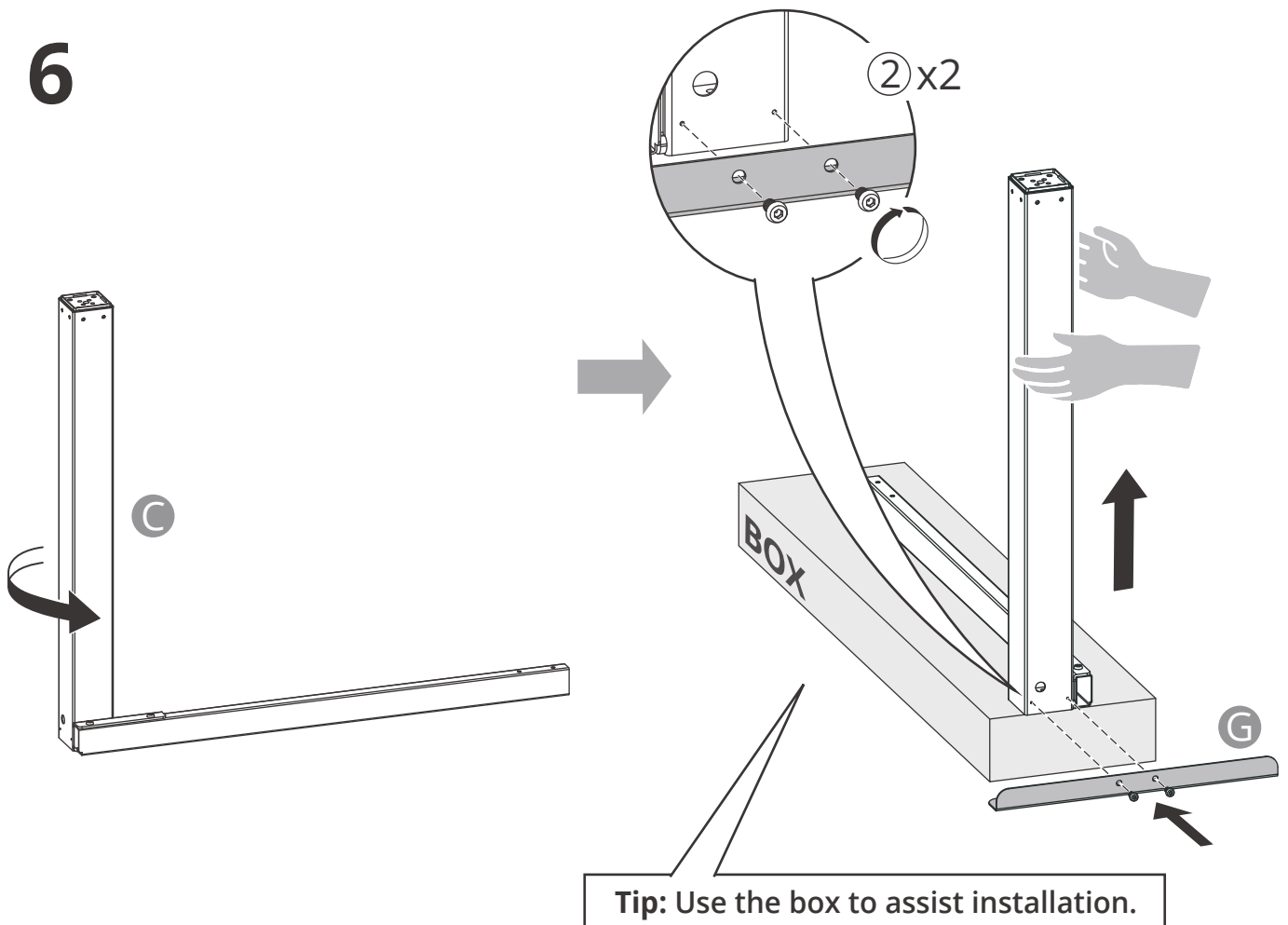

7

Note: Direction of connectors.

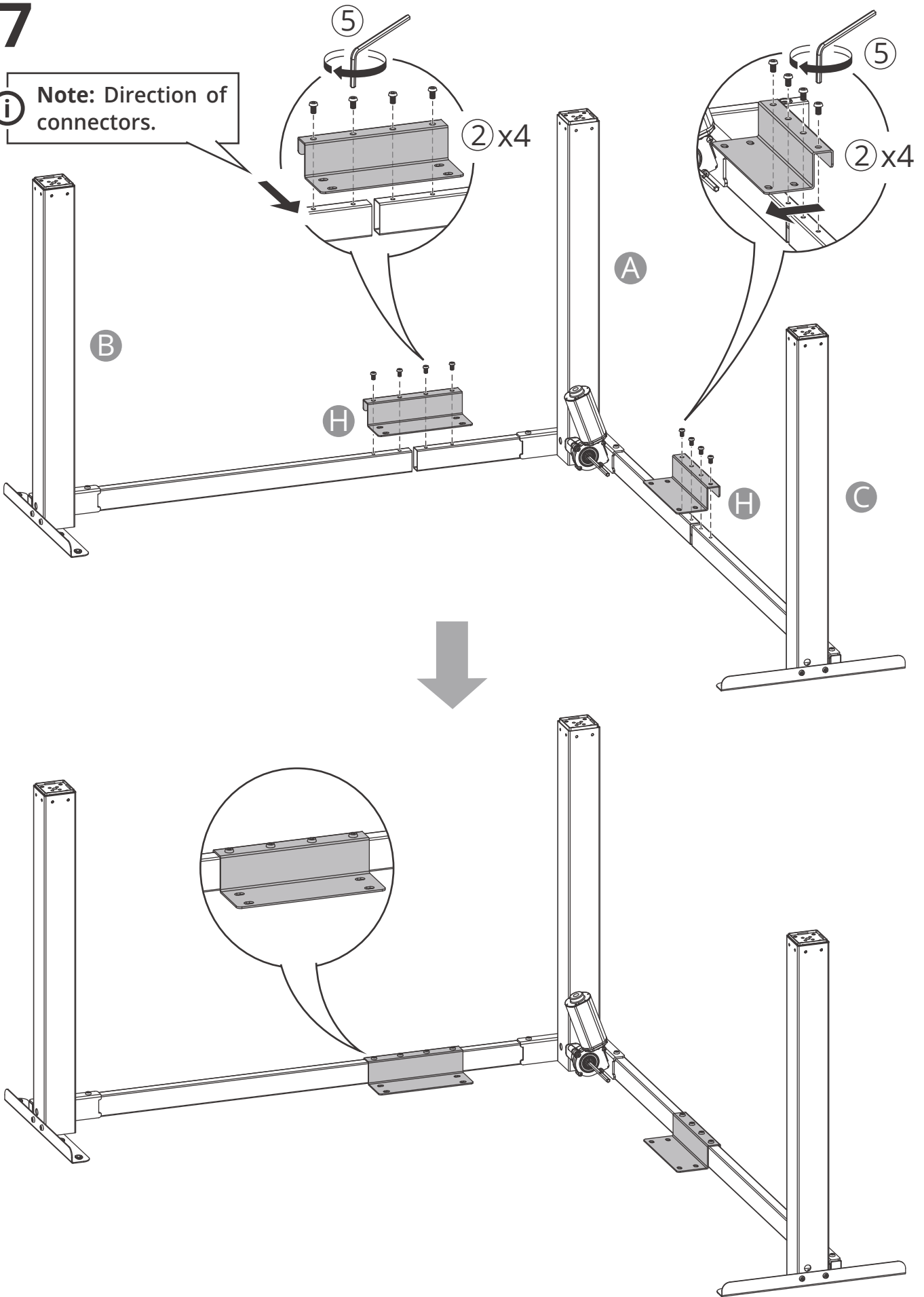

8

i Note: Please place the tabletop on the carpet for installation to prevent scratching the tabletop.

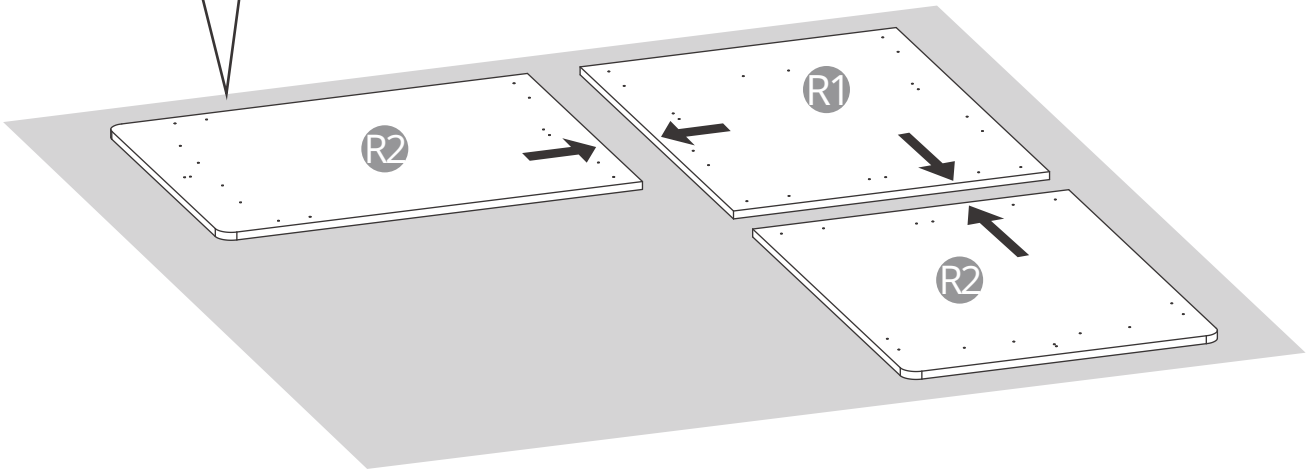

9

i Note: Please tighten screws gently to 4-5 N.m. Do not overtighten.

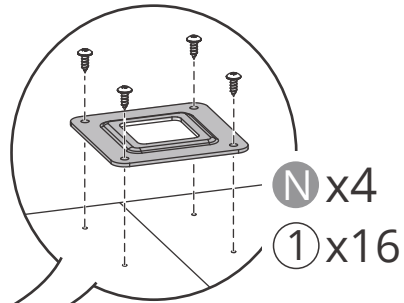

Join firmly together

Join firmly together

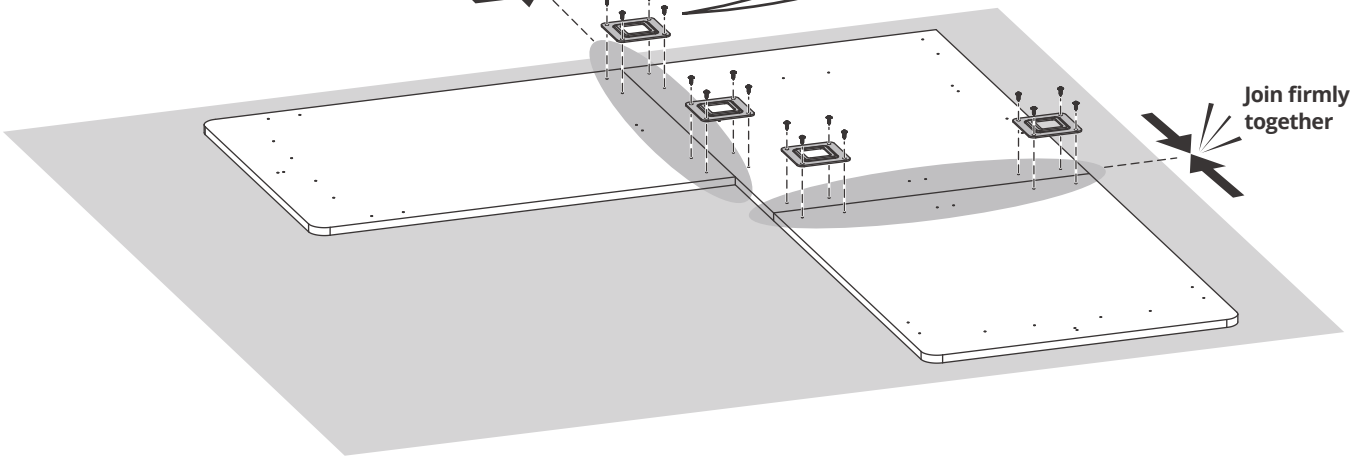

10

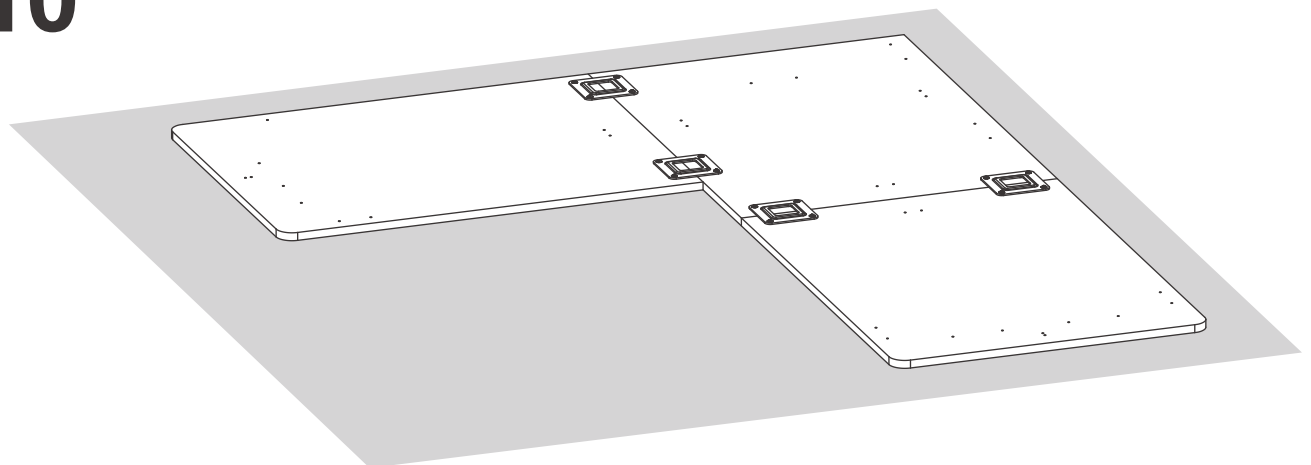

11

i Note: Enjoy the freedom to mount the hand set on either left / right side beneath the desktop.

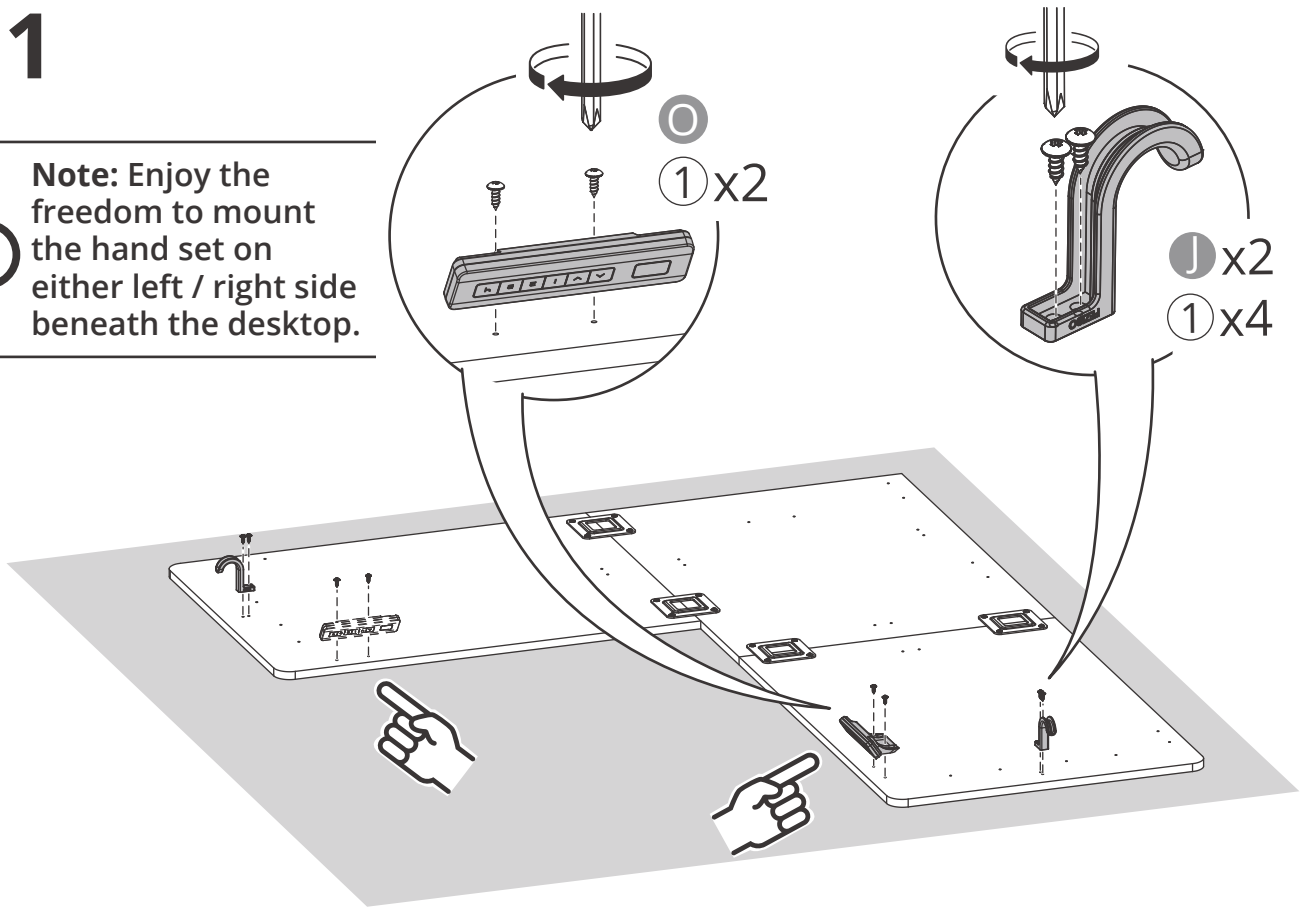

12

i Ensure all holes are aligned before tightening the screws.

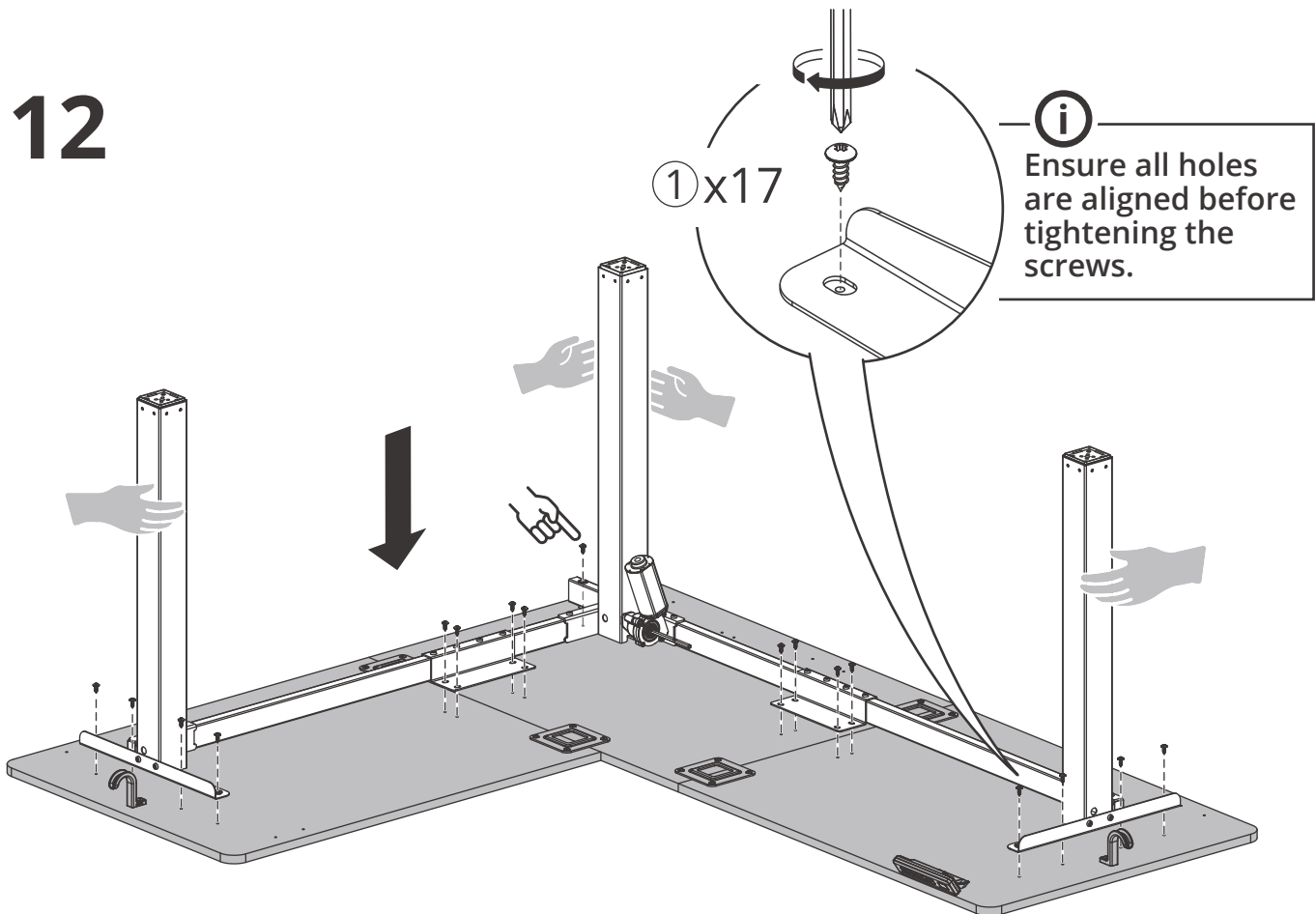

13



Note: Align and fully insert the hexagonal sync rod until the locking point engages to avoid uneven height adjustment.

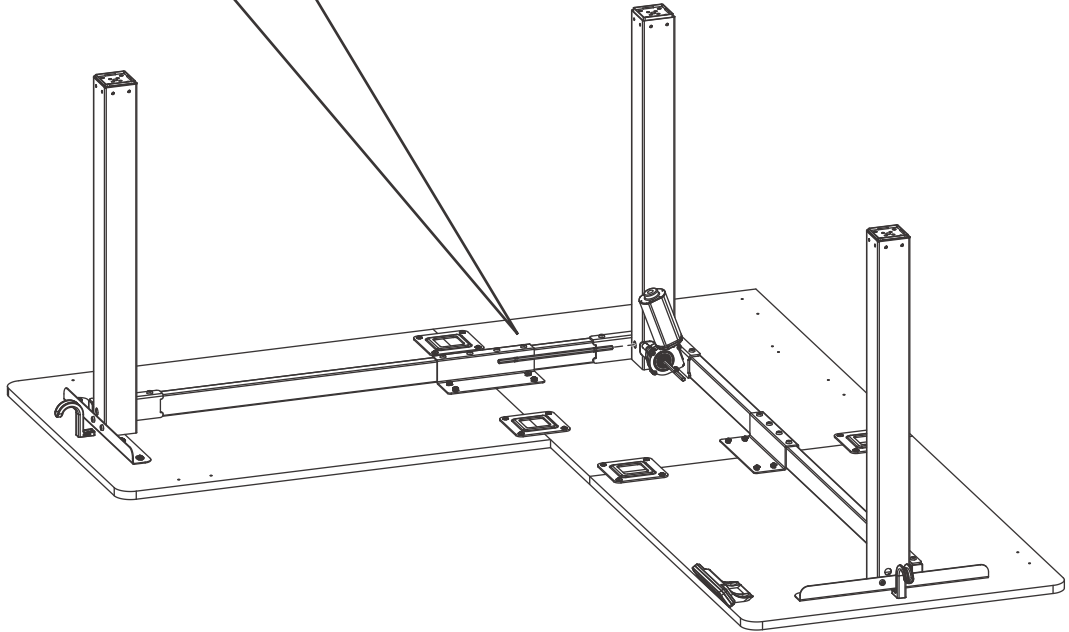
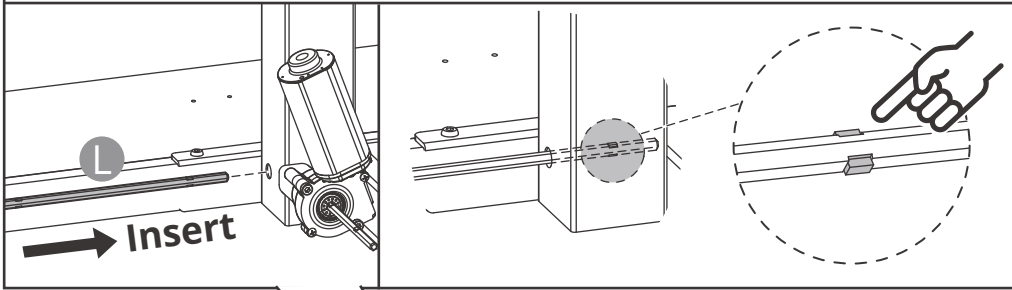

14

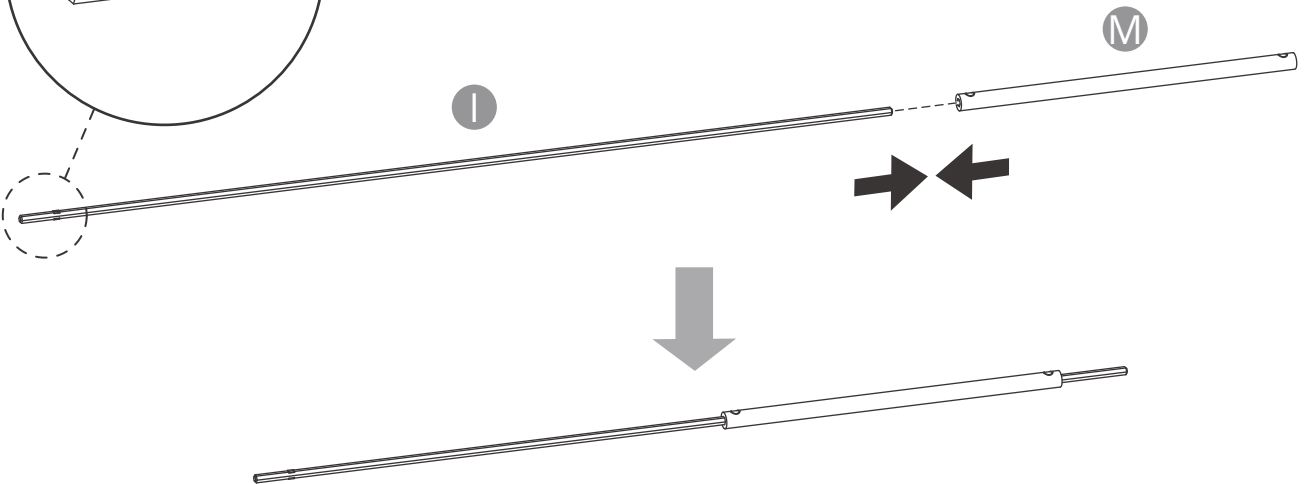
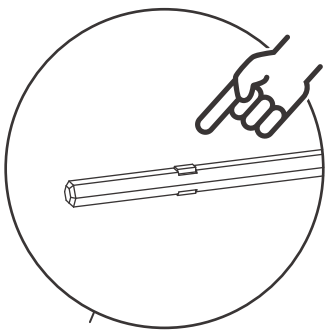

15

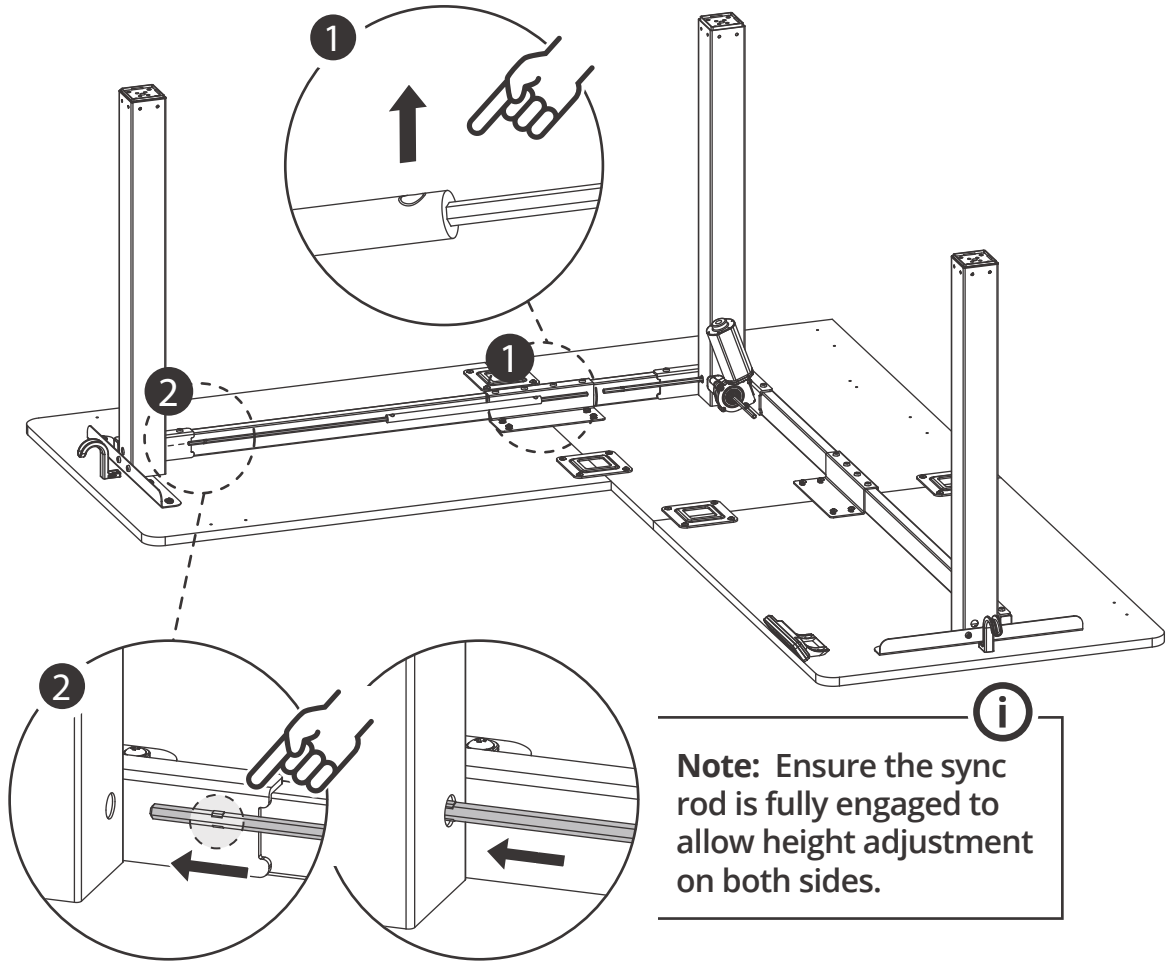

16

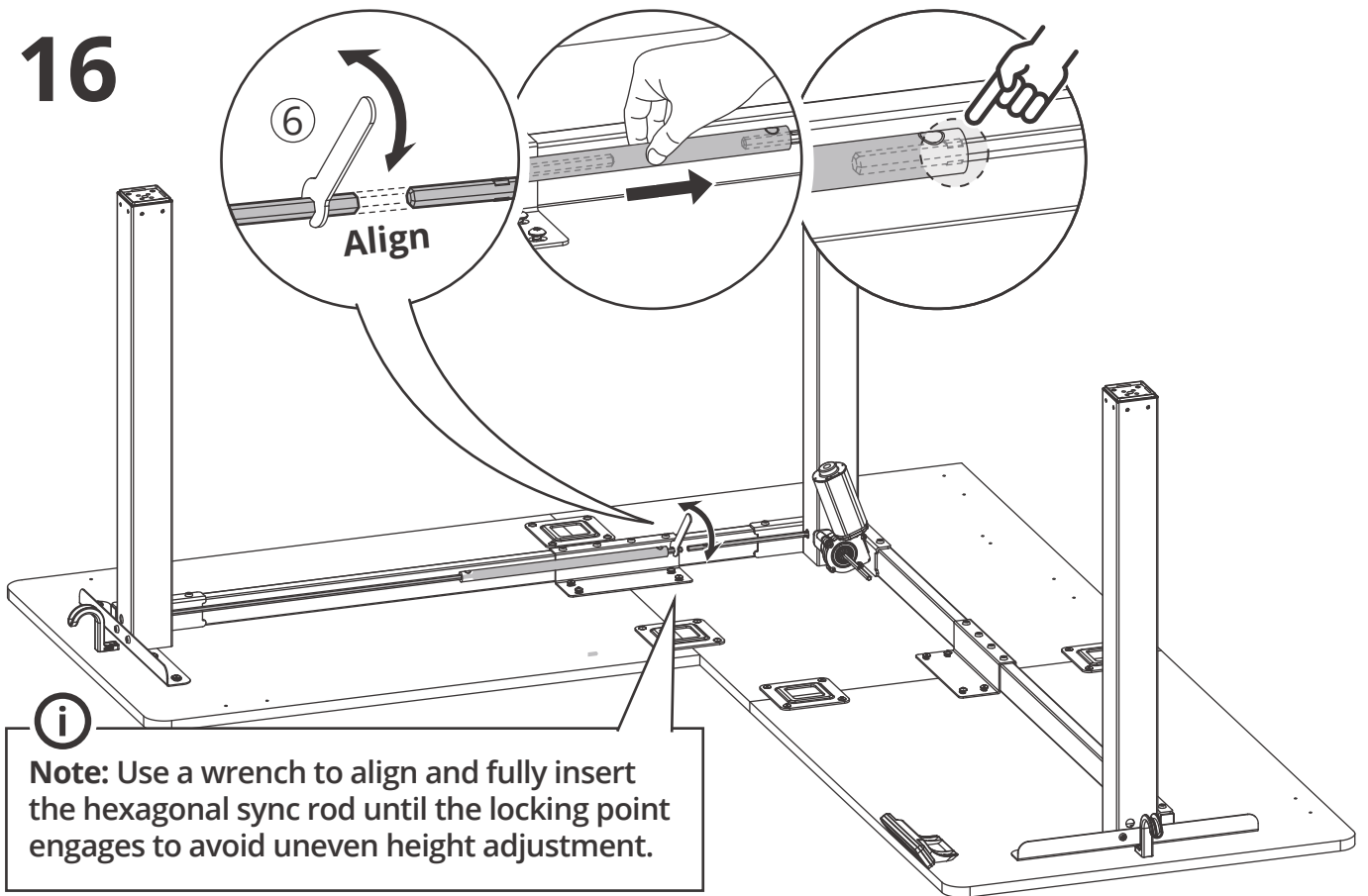

17

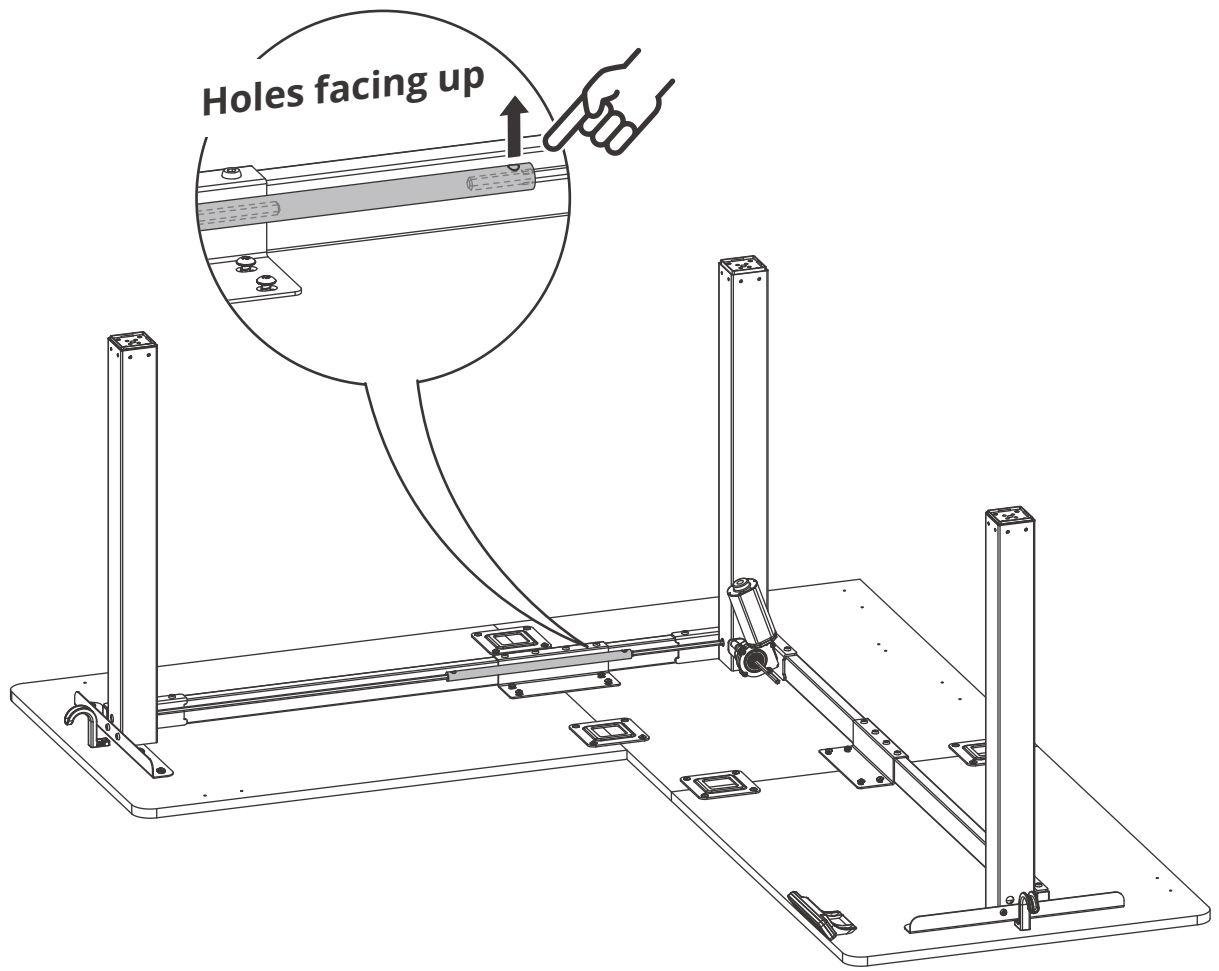

18

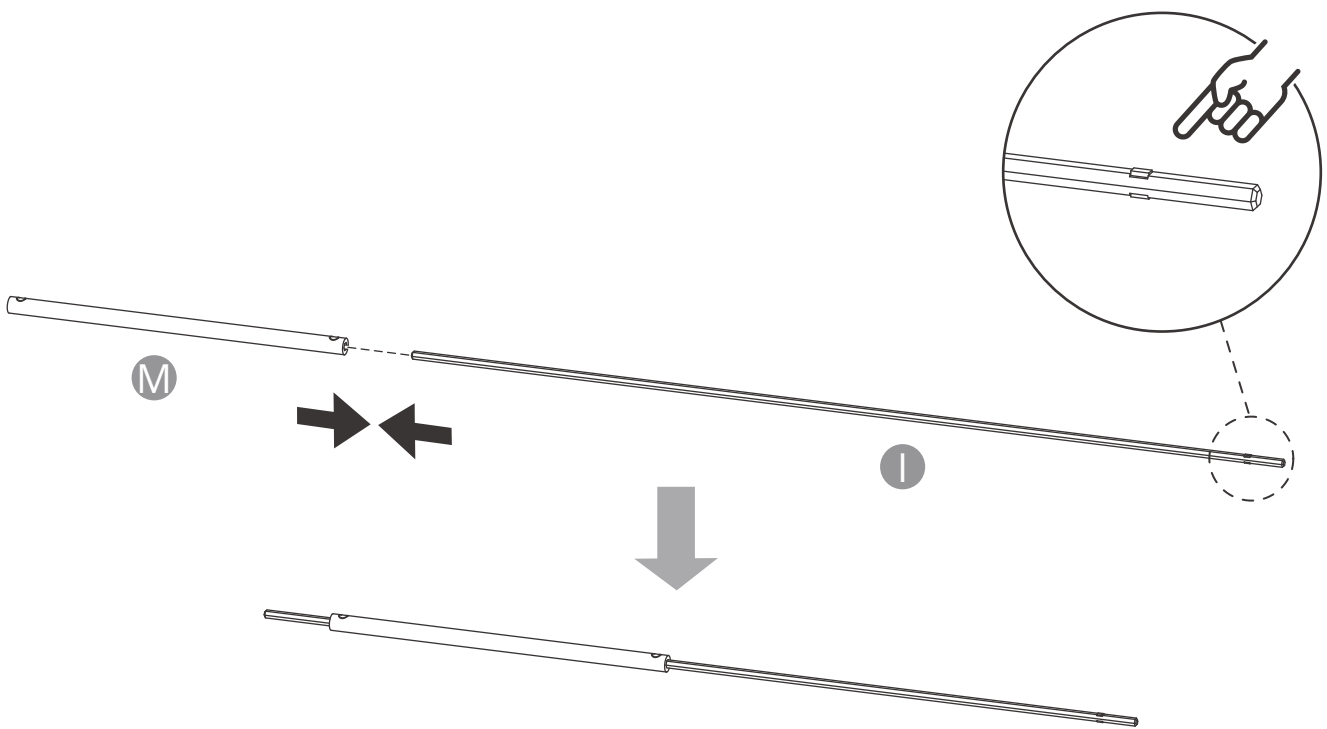

19

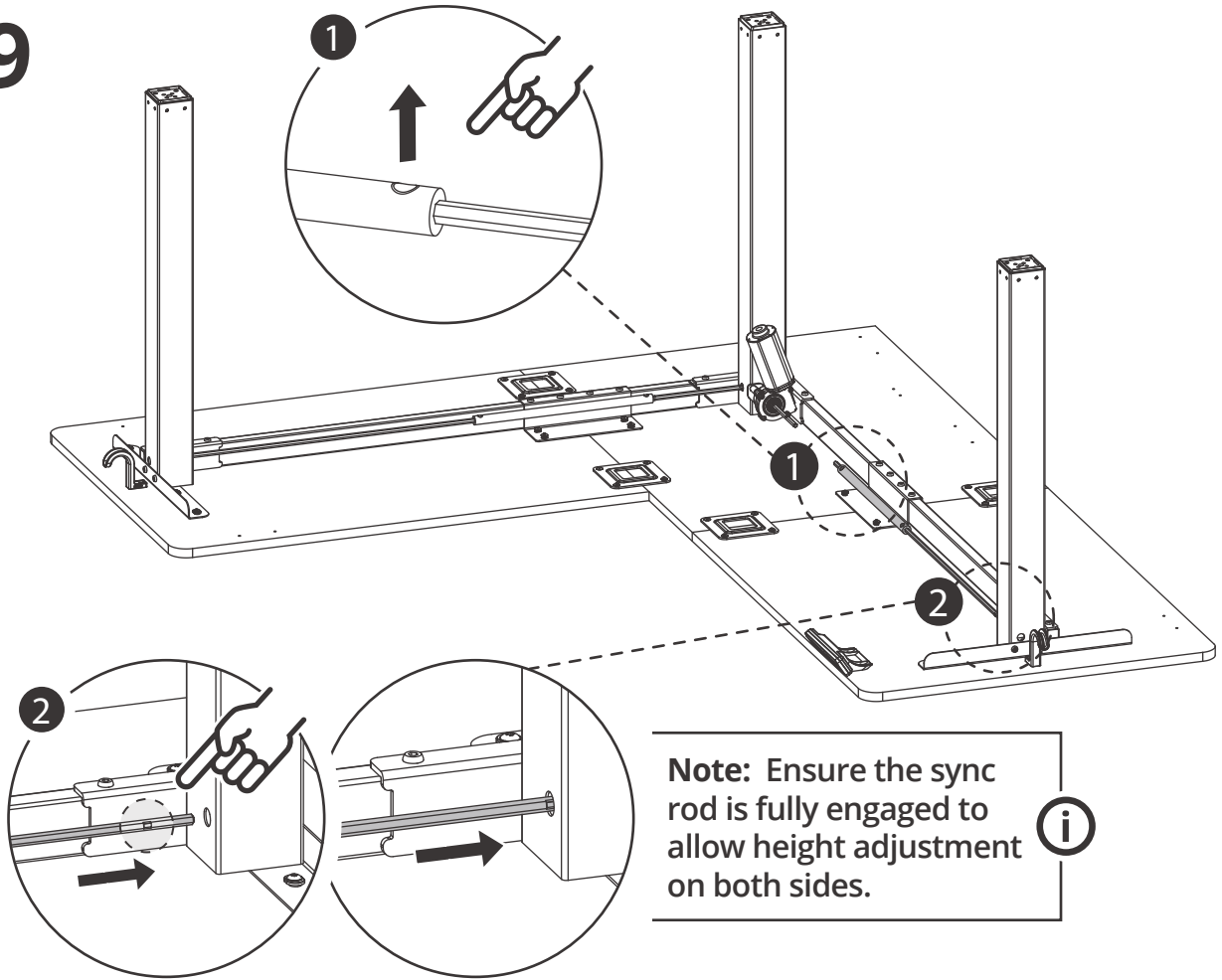

20

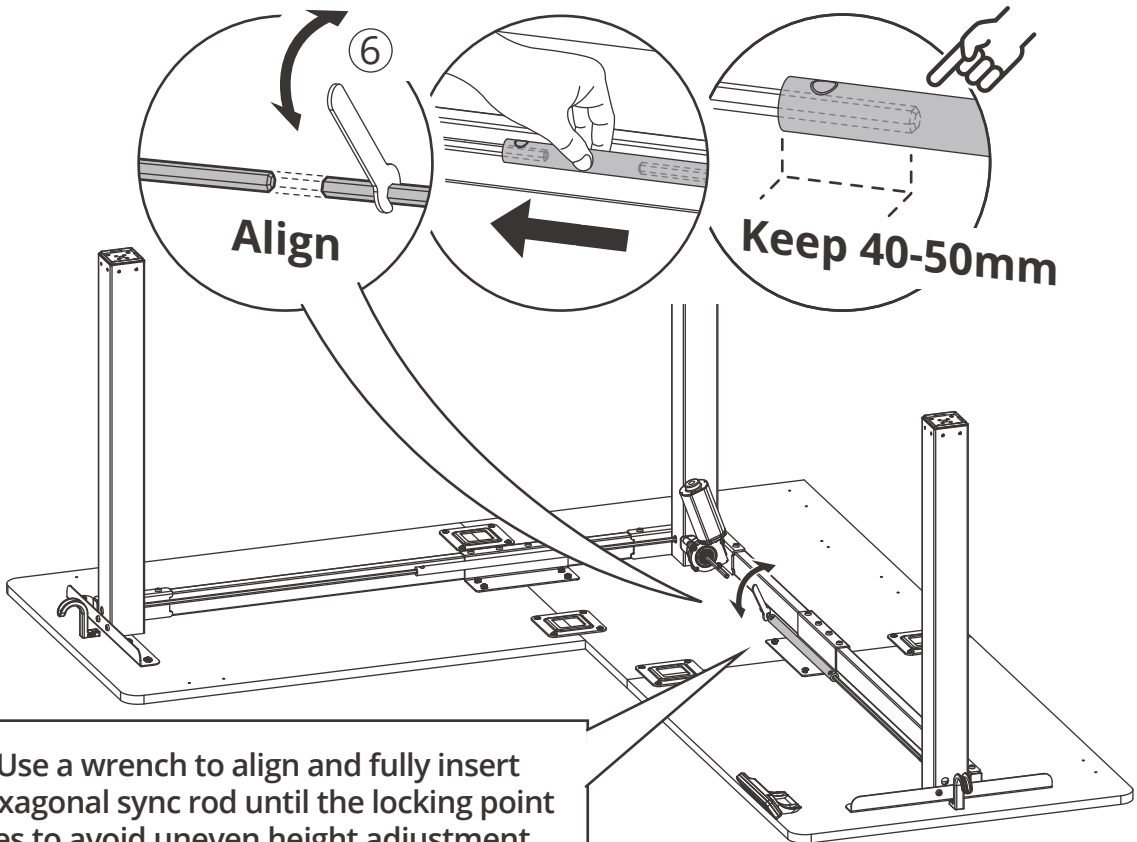

21

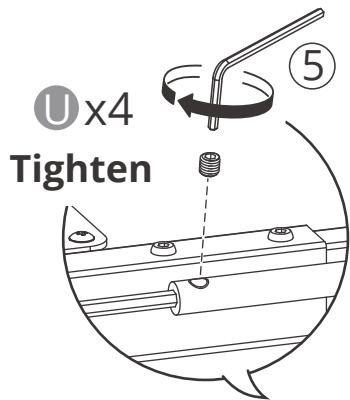

Tighten

i Note: Tighten set screws to avoid gap and abnormal noise.

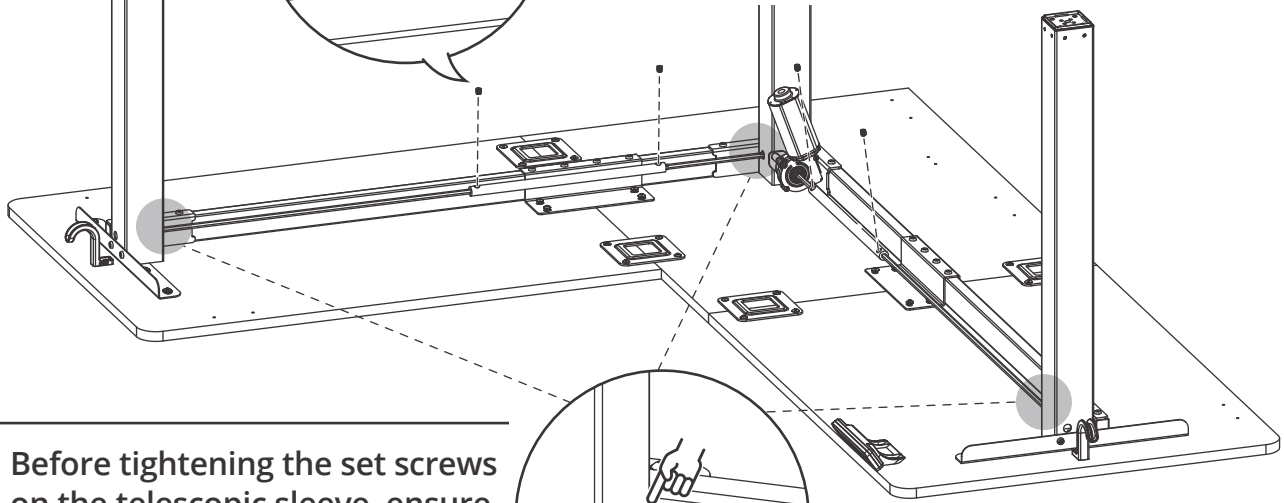

i Before tightening the set screws on the telescopic sleeve, ensure all limit stops on the sync rod are correctly positioned.

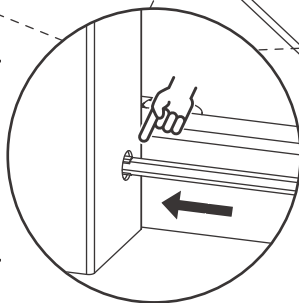

22

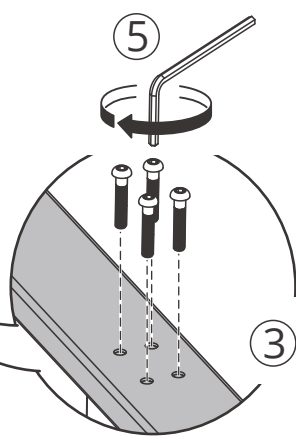

3 x 12

i Ensure the short foot is parallel to the long foot of the longer desktop.

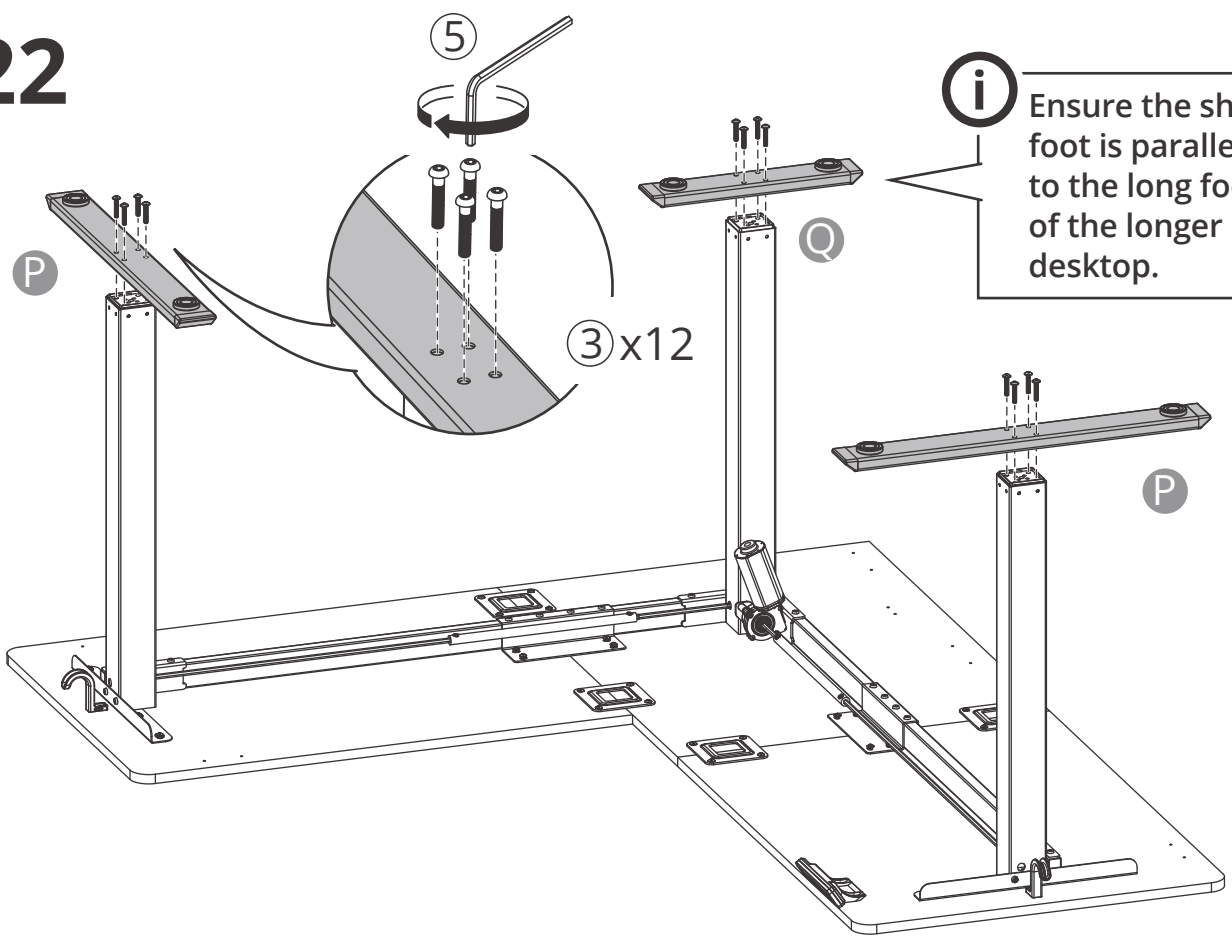

23

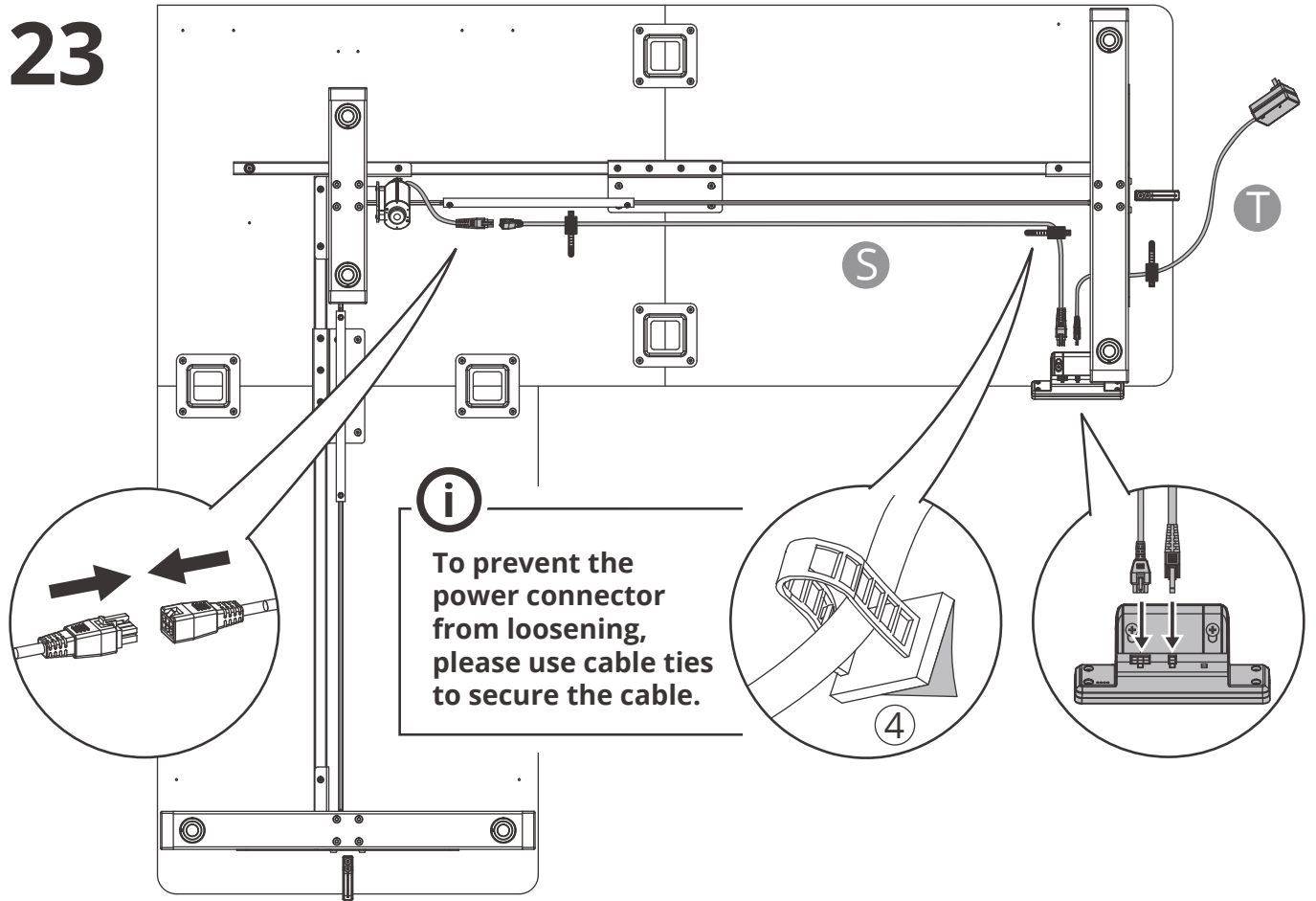

24

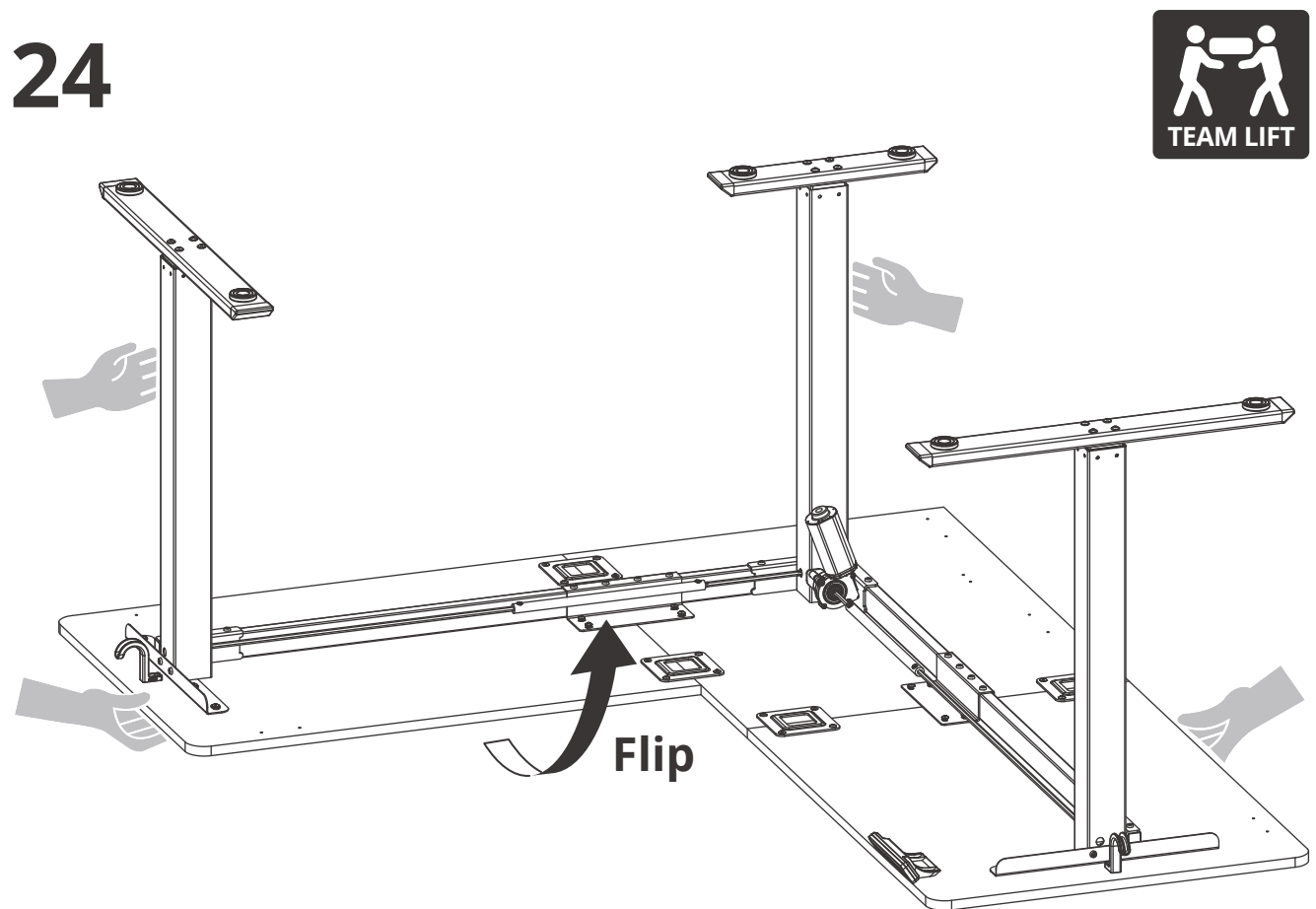

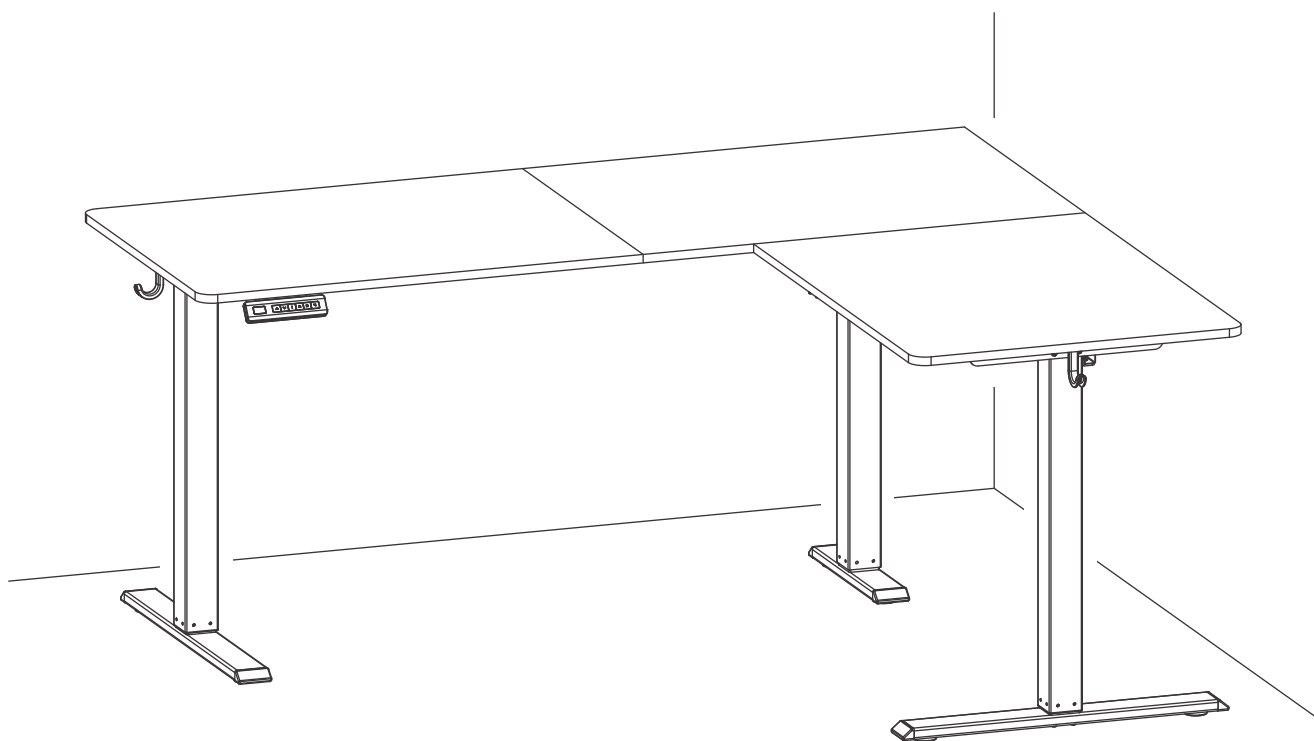

Handset Instructions & FAQ

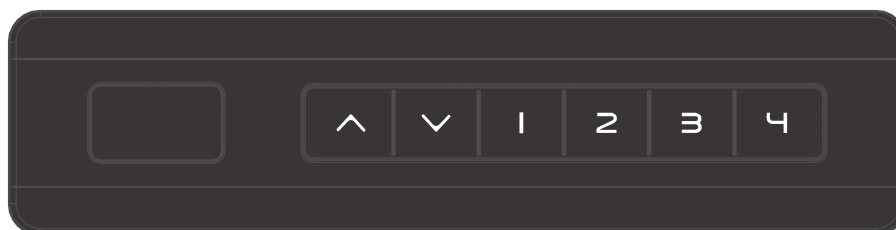

English	34 - 35
Deutsch	36 - 37
Français	38 - 39
Español	40 - 41
Italiano	42 - 43

Keypad User Guide



Height Adjustment

Press and hold the **^** or **v** button to adjust the height.



Memory Heights

1. Briefly press the memory button **1** / **2** / **3** / **4** . The desk will automatically move to the corresponding preset height.
2. Default memory key heights: Key **1** : 28.3 in (72/73 cm), Key **2** : 35.4 in (89/90 cm), Key **3** : 41.3 in (104/105 cm), Key **4** : 46.4 in (117/118 cm).



Memory Height Setting

Press and hold the **^** or **v** button to adjust the desk to the desired height. Press and hold the **1** / **2** / **3** / **4** button for 3 seconds until the numbers on the display start flashing, indicating that the current height has been successfully saved.



Child Lock

1. Lock: Simultaneously press and hold the **1** and **2** buttons for 3 seconds. When the display shows "Loc," the desk is locked and cannot be adjusted.
2. Unlock: Simultaneously press and hold the **1** and **2** buttons for 3 seconds. When the display changes from "Loc" to showing the desk height, the child lock is released.



Reset

1. Press and hold **v** to lower the desktop to its lowest achievable position, then release.
2. Press and hold **v** for 5 seconds until "RST" appears, then release.
3. Press and hold **v** again: The desktop will lower further and rebound, and the current height will be displayed. Release the button to complete the reset.

Frequently Asked Questions (FAQ)

One-Sided Desk Lifting

Possible Cause

The sync rod is not installed correctly.

Solution

Check if the sync rod is fully inserted into the leg column. If not, lower the desk to its lowest position and reinstall the sync rod referring to the leg installation sticker or the instruction manual.

If the above steps do not solve the problem, please take a video of the issue and contact after-sales support at support@yfs.life.

<p>Handset Malfunction or No Response</p>	<p>Possible Causes</p> <ol style="list-style-type: none"> 1. Power is not connected correctly. 2. Controller has poor contact or is malfunctioning. 3. Fuse is blown or the power module is faulty. <p>Solution</p> <p>Disconnect all cable connections and reconnect them. Check if all cables are connected correctly and tightly. Make sure the power plug is inserted into the power outlet.</p> <p>If the above steps do not solve the problem, please take a video of the issue and contact after-sales support at support@yfs.life.</p>
<p>Desk Tilting or Unbalanced</p>	<p>Possible Causes</p> <ol style="list-style-type: none"> 1. Improper installation causing imbalance. 2. One column or footpad is not level. <p>Solution</p> <ol style="list-style-type: none"> 1. Review the installation steps to ensure each column is correctly installed and the desk is level. 2. Adjust the footpad height to level the desk. 3. If unresolved, record a video of the issue and contact customer support at support@yfs.life.
<p>Unusual Noise or Irregular Movement During Height Adjustment</p>	<p>Possible Causes</p> <ol style="list-style-type: none"> 1. The desktop load exceeds the recommended limit (not more than 100 kg / 220 lbs). 2. Loose connections in the desk—especially near the sync rod. 3. The motor may be faulty. <p>Solution</p> <ol style="list-style-type: none"> 1. Check if the items on the desktop exceed the weight limit and reduce the load if necessary. 2. Inspect and tighten all screws and connectors to secure the desk structure. 3. If the issue persists after these steps, record a video of the problem and contact customer support at support@yfs.life.
<p>Handset displays "RST," "E07," or "E08"</p>	<p>Possible Cause</p> <p>Poor connection of the motor cable.</p> <p>Solution</p> <p>Verify that all cable connections are correct and secure, and then perform a reset.</p> <p>If the problem persists, please take a video of the issue and contact after-sales support at support@yfs.life.</p>
<p>Handset displays "HOT"</p>	<p>Possible Cause</p> <p>The desk has entered overheat protection mode.</p> <p>Solution</p> <p>Wait 20 minutes before operating the desk. If the problem persists, please take a video of the issue and contact after-sales support at support@yfs.life.</p>

Deutsch



Höhenverstellung

Drücken und halten Sie die \wedge oder \vee Taste, um die Schreibtischhöhe einzustellen.



Speicherhöhenbedienung

1. Drücken Sie kurz die Speichertaste **1** / **2** / **3** / **4**. Der Schreibtisch fährt automatisch auf die entsprechende voreingestellte Höhe.

2. Standardhöhen der Speichertasten: Taste **1**: 72/73 cm, Taste **2**: 89/90 cm, Taste **3**: 104/105 cm, Taste **4**: 117/118 cm.



Speicherhöheneinstellung

Drücken und halten Sie die \wedge oder \vee Taste, um den Schreibtisch auf die gewünschte Höhe einzustellen. Drücken und halten Sie die **1** / **2** / **3** / **4** Taste 3 Sekunden lang, bis die Zahlen auf dem Display zu blinken beginnen, was bedeutet, dass die aktuelle Höhe erfolgreich gespeichert wurde.



Kindersicherung

1. Sperren: Drücken und halten Sie gleichzeitig die Tasten **1** und **2** für 3 Sekunden. Wenn das Display "Loc" anzeigt, ist der Schreibtisch gesperrt und kann nicht verstellt werden.

2. Entsperren: Drücken und halten Sie gleichzeitig die Tasten **1** und **2** für 3 Sekunden. Wenn das Display von "Loc" zu der Anzeige der Schreibtischhöhe wechselt, ist die Kindersicherung aufgehoben.



Zurücksetzen

1. Drücken und halten Sie \vee , um die Tischplatte in ihre niedrigste erreichbare Position zu senken, und lassen Sie dann los.

2. Drücken und halten Sie \vee 5 Sekunden lang, bis "RST" angezeigt wird, und lassen Sie dann los.

3. Drücken und halten Sie \vee erneut: Die Tischplatte senkt sich weiter ab und springt zurück, und die aktuelle Höhe wird angezeigt. Lassen Sie die Taste los, um den Reset abzuschließen.

Häufig gestellte Fragen (FAQ)

Einseitige Tischhöhenverstellung

Mögliche Ursache:

Die Synchronisationsstange ist nicht richtig installiert.

Lösung:

Prüfen Sie, ob die Synchronisationsstange vollständig in die Beinsäule eingeführt ist. Wenn nicht, senken Sie den Schreibtisch in seine niedrigste Position und installieren Sie die Synchronisationsstange neu, indem Sie sich auf den Aufkleber an der Beininstallation oder die Bedienungsanleitung beziehen.

Wenn die obigen Schritte das Problem nicht lösen, machen Sie bitte ein Video des Problems und kontaktieren Sie den After-Sales-Support unter support@yfs.life.

<p>Hörer funktioniert nicht oder reagiert nicht</p>	<p>Mögliche Ursachen:</p> <ol style="list-style-type: none"> 1. Die Stromversorgung ist nicht richtig angeschlossen. 2. Der Controller hat schlechten Kontakt oder ist defekt. 3. Die Sicherung ist durchgebrannt oder das Netzteilmodul ist defekt. <p>Lösung:</p> <p>Trennen Sie alle Kabelverbindungen und verbinden Sie sie wieder. Prüfen Sie, ob alle Kabelschnittstellen richtig und fest verbunden sind. Stellen Sie sicher, dass der Netzstecker in die Steckdose eingesteckt ist.</p> <p>Wenn die obigen Schritte das Problem nicht lösen, machen Sie bitte ein Video des Problems und kontaktieren Sie den After-Sales-Support unter support@yfs.life.</p>
<p>Der Schreibtisch ist schief oder unausgeglichen</p>	<p>Mögliche Ursachen:</p> <ol style="list-style-type: none"> 1. Eine fehlerhafte Montage führt zu einem Ungleichgewicht. 2. Ein Tischbein oder eine Fußplatte befindet sich nicht auf derselben Ebene. <p>Lösung:</p> <ol style="list-style-type: none"> 1. Überprüfen Sie die Montageschritte, um sicherzustellen, dass jedes Bein korrekt installiert ist und der Schreibtisch waagrecht steht. 2. Passen Sie die Höhe der Fußplatten an, um den Schreibtisch auszurichten. 3. Falls das Problem nicht behoben wird, nehmen Sie ein Video der Störung auf und kontaktieren Sie den Kundendienst unter support@yfs.life.
<p>Ungewöhnliche Geräusche oder ruckartige Bewegungen während der Höhenverstellung</p>	<p>Mögliche Ursachen:</p> <ol style="list-style-type: none"> 1. Die Belastung des Desktops überschreitet das empfohlene Limit (nicht mehr als 100 kg). 2. Einige Verbindungen, insbesondere in der Nähe des Sync-Rods, sind locker. 3. Der Motor ist möglicherweise defekt. <p>Lösung:</p> <ol style="list-style-type: none"> 1. Überprüfen Sie, ob die auf dem Desktop platzierten Gegenstände das Gewichtslimit überschreiten, und reduzieren Sie gegebenenfalls die Last. 2. Ziehen Sie alle Schrauben und Verbindungen nach, um die Stabilität der Struktur zu gewährleisten. 3. Wenn das Problem nach diesen Schritten weiterhin besteht, nehmen Sie ein Video der Störung auf und kontaktieren Sie den Kundendienst unter support@yfs.life.
<p>Das Handset zeigt "RST", "E07" oder "E08" an</p>	<p>Mögliche Ursache:</p> <p>Schlechter Kontakt des Motorkabels.</p> <p>Lösung:</p> <p>Überprüfen Sie, ob alle Kabelverbindungen korrekt und sicher sind, und führen Sie dann einen Reset durch. Wenn das Problem weiterhin besteht, machen Sie bitte ein Video des Problems und kontaktieren Sie den After-Sales-Support unter support@yfs.life.</p>
<p>Das Handset zeigt "HOT" an</p>	<p>Mögliche Ursache:</p> <p>Der Schreibtisch ist in den Überhitzungsschutzmodus eingetreten.</p> <p>Lösung:</p> <p>Warten Sie 20 Minuten, bevor Sie den Schreibtisch bedienen. Wenn das Problem weiterhin besteht, machen Sie bitte ein Video des Problems und kontaktieren Sie den After-Sales-Support unter support@yfs.life.</p>

Français



Réglage de la hauteur

Appuyez et maintenez enfoncé le bouton **▲** ou **▼** pour régler la hauteur du bureau.



Fonctionnement de la hauteur mémorisée

1. Appuyez brièvement sur le bouton de mémoire **1** / **2** / **3** / **4**. Le bureau se déplacera automatiquement à la hauteur pré-réglée correspondante.

2. Hauteurs par défaut des touches de mémoire: Touche **1**: 72/73 cm, Touche **2**: 89/90 cm, Touche **3**: 104/105 cm, Touche **4**: 117/118 cm.



Réglage de la hauteur mémorisée

Appuyez et maintenez enfoncé le bouton **▲** ou **▼** pour régler le bureau à la hauteur souhaitée. Appuyez et maintenez enfoncé le bouton **1** / **2** / **3** / **4** pendant 3 secondes jusqu'à ce que les chiffres sur l'écran commencent à clignoter, indiquant que la hauteur actuelle a été enregistrée avec succès.



Verrouillage enfant

1. Verrouillage: Appuyez et maintenez enfoncés simultanément les boutons **1** et **2** pendant 3 secondes. Lorsque l'écran affiche "Loc", le bureau est verrouillé et ne peut pas être réglé.

2. Déverrouillage: Appuyez et maintenez enfoncés simultanément les boutons **1** et **2** pendant 3 secondes. Lorsque l'écran passe de "Loc" à l'affichage de la hauteur du bureau, le verrouillage enfant est désactivé.



Réinitialisation

1. Appuyez et maintenez **▼** pour abaisser le plateau à sa position la plus basse atteignable, puis relâchez.

2. Appuyez et maintenez **▼** pendant 5 secondes jusqu'à ce que "RST" apparaisse, puis relâchez.

3. Appuyez et maintenez **▼** à nouveau: le plateau s'abaissera davantage et remontera, et la hauteur actuelle s'affichera. Relâchez le bouton pour terminer la réinitialisation.

Questions Fréquemment Posées (FAQ)

Levage unilatéral du bureau

Cause Possible:

La tige de synchronisation n'est pas installée correctement.

Solution:

Vérifiez si la tige de synchronisation est complètement insérée dans la colonne de la jambe. Si ce n'est pas le cas, abaissez le bureau à sa position la plus basse et réinstallez la tige de synchronisation en vous référant à l'autocollant d'installation de la jambe ou au manuel d'instructions.

Si les étapes ci-dessus ne résolvent pas le problème, veuillez faire une vidéo du problème et contacter le support après-vente à support@yfs.life.

<p>Le combiné ne fonctionne pas ou ne répond pas</p>	<p>Causes Possibles:</p> <ol style="list-style-type: none"> 1. L'alimentation n'est pas connectée correctement. 2. Le contrôleur a un mauvais contact ou est défectueux. 3. Le fusible est grillé ou le module d'alimentation est défectueux. <p>Solution:</p> <p>Déconnectez toutes les connexions de câble et reconnectez-les. Vérifiez si toutes les interfaces de câble sont connectées correctement et fermement. Assurez-vous que la fiche d'alimentation est insérée dans la prise de courant.</p> <p>Si les étapes ci-dessus ne résolvent pas le problème, veuillez faire une vidéo du problème et contacter le support après-vente à support@yfs.life.</p>
<p>Le bureau est incliné ou déséquilibré</p>	<p>Causes possibles:</p> <ol style="list-style-type: none"> 1. Une installation incorrecte entraîne un déséquilibre. 2. Un des pieds ou patins n'est pas aligné au même niveau. <p>Solution:</p> <ol style="list-style-type: none"> 1. Revoyez les étapes d'installation pour vous assurer que chaque pied est correctement fixé et que le bureau est de niveau. 2. Ajustez la hauteur des patins pour rétablir l'équilibre du bureau. 3. Si le problème n'est pas résolu, enregistrez une vidéo du dysfonctionnement et contactez le service client à support@yfs.life.
<p>Bruits inhabituels ou fonctionnement irrégulier lors du réglage de la hauteur</p>	<p>Causes possibles:</p> <ol style="list-style-type: none"> 1. La charge sur le desktop dépasse la limite recommandée (ne pas excéder 100 kg). 2. Certaines connexions du bureau, notamment près de la tige de synchronisation, sont desserrées. 3. Le moteur peut être défectueux. <p>Solution:</p> <ol style="list-style-type: none"> 1. Vérifiez si les objets sur le desktop dépassent le poids recommandé et réduisez la charge si nécessaire. 2. Vérifiez et resserrez toutes les vis et connexions pour assurer la stabilité de la structure du bureau. 3. Si le problème persiste, enregistrez une vidéo du dysfonctionnement et contactez le service client à support@yfs.life.
<p>Le combiné affiche "RST", "E07" ou "E08"</p>	<p>Cause Possible:</p> <p>Mauvais contact du câble du moteur.</p> <p>Solution:</p> <p>Vérifiez que toutes les connexions de câble sont correctes et sécurisées, puis effectuez une réinitialisation. Si le problème persiste, veuillez faire une vidéo du problème et contacter le support après-vente à support@yfs.life.</p>
<p>Le combiné affiche "HOT"</p>	<p>Cause Possible:</p> <p>Le bureau est entré en mode de protection contre la surchauffe.</p> <p>Solution:</p> <p>Attendez 20 minutes avant d'utiliser le bureau. Si le problème persiste, veuillez faire une vidéo du problème et contacter le support après-vente à support@yfs.life.</p>

Español



Ajuste de altura

Mantenga presionado el botón **^** o **v** para ajustar la altura del escritorio.

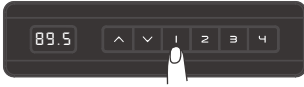

Funcionamiento de altura de memoria

1. Presione brevemente el botón de memoria **1** / **2** / **3** / **4** . El escritorio se moverá automáticamente a la altura preestablecida correspondiente.

2. Alturas predeterminadas de las teclas de memoria: Tecla **1** : 72/73 cm, Tecla **2** : 89/90 cm, Tecla **3** : 104/105 cm, Tecla **4** : 117/118 cm.



Configuración de altura de memoria

Mantenga presionado el botón **^** o **v** para ajustar el escritorio a la altura deseada. Mantenga presionado el botón **1** / **2** / **3** / **4** durante 3 segundos hasta que los números en la pantalla comiencen a parpadear, indicando que la altura actual se ha guardado correctamente.



Bloqueo infantil

1. Bloqueo: Mantenga presionados simultáneamente los botones **1** y **2** durante 3 segundos. Cuando la pantalla muestra "Loc", el escritorio está bloqueado y no se puede ajustar.

2. Desbloqueo: Mantenga presionados simultáneamente los botones **1** y **2** durante 3 segundos. Cuando la pantalla cambia de "Loc" a mostrar la altura del escritorio, el bloqueo infantil se desactiva.



Restablecimiento

1. Mantenga presionado **v** para bajar el tablero a su posición más baja alcanzable, luego suelte.

2. Mantenga presionado **v** durante 5 segundos hasta que aparezca "RST", luego suelte.

3. Mantenga presionado **v** nuevamente: el tablero bajará aún más y rebotará, y se mostrará la altura actual. Suelte el botón para completar el restablecimiento.

Preguntas Frecuentes (FAQ)

Elevación unilateral del escritorio

Posible Causa:

La varilla de sincronización no está instalada correctamente.

Solución:

Verifique si la varilla de sincronización está completamente insertada en la columna de la pata. Si no, baje el escritorio a su posición más baja y vuelva a instalar la varilla de sincronización consultando la etiqueta de instalación de la pata o el manual de instrucciones.

Si los pasos anteriores no resuelven el problema, haga un video del problema y póngase en contacto con el soporte posventa en support@yfs.life.

<p>El teléfono no funciona o no responde</p>	<p>Posibles Causas:</p> <ol style="list-style-type: none"> 1. La alimentación no está conectada correctamente. 2. El controlador tiene mal contacto o no funciona correctamente. 3. El fusible está fundido o el módulo de alimentación está defectuoso. <p>Solución:</p> <p>Desconecte todas las conexiones de cables y vuelva a conectarlas. Verifique si todas las interfaces de cables están conectadas correcta y firmemente. Asegúrese de que el enchufe de alimentación esté insertado en la toma de corriente.</p> <p>Si los pasos anteriores no resuelven el problema, haga un video del problema y póngase en contacto con el soporte posventa en support@yfs.life.</p>
<p>El escritorio está inclinado o desequilibrado</p>	<p>Posibles causas:</p> <ol style="list-style-type: none"> 1. Una instalación incorrecta que causa desequilibrio. 2. Una de las patas o almohadillas no está al mismo nivel. <p>Solución:</p> <ol style="list-style-type: none"> 1. Revise los pasos de instalación para asegurarse de que cada pata esté instalada correctamente y el escritorio esté nivelado. 2. Ajuste la altura de las almohadillas para restablecer el equilibrio. 3. Si el problema persiste, grabe un video del fallo y contacte al servicio de atención al cliente en support@yfs.life.
<p>Ruidos inusuales o movimiento irregular durante el ajuste de altura</p>	<p>Posibles causas:</p> <ol style="list-style-type: none"> 1. La carga sobre el desktop supera el límite recomendado (no más de 100 kg). 2. Algunas conexiones del escritorio, especialmente cerca de la barra de sincronización, están flojas. 3. El motor puede estar defectuoso. <p>Solución:</p> <ol style="list-style-type: none"> 1. Verifique si los objetos sobre el desktop exceden el límite de peso y reduzca la carga si es necesario. 2. Revise y apriete todos los tornillos y conectores para asegurar la estabilidad de la estructura. 3. Si el problema persiste, grabe un video del fallo y contacte al servicio de atención al cliente en support@yfs.life.
<p>El teléfono muestra "RST", "E07" o "E08"</p>	<p>Posible Causa:</p> <p>Mala conexión del cable del motor.</p> <p>Solución:</p> <p>Verifique que todas las conexiones de cables sean correctas y seguras, luego realice un restablecimiento. Si el problema persiste, haga un video del problema y póngase en contacto con el soporte posventa en support@yfs.life.</p>
<p>El teléfono muestra "HOT"</p>	<p>Posible Causa:</p> <p>El escritorio ha entrado en modo de protección contra sobrecalentamiento.</p> <p>Solución:</p> <p>Espere 20 minutos antes de operar el escritorio. Si el problema persiste, haga un video del problema y póngase en contacto con el soporte posventa en support@yfs.life.</p>



Regolazione dell'altezza

Tenere premuto il pulsante **^** o **v** per regolare l'altezza della scrivania.

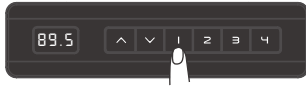

Funzionamento dell'altezza memorizzata

1. Premere brevemente il pulsante di memoria **1** / **2** / **3** / **4**. La scrivania si sposterà automaticamente all'altezza preimpostata corrispondente.

2. Altezze predefinite dei tasti di memoria: Tasto **1**: 72/73 cm, Tasto **2**: 89/90 cm, Tasto **3**: 104/105 cm, Tasto **4**: 117/118 cm.



Impostazione dell'altezza memorizzata

Tenere premuto il pulsante **^** o **v** per regolare la scrivania all'altezza desiderata. Tenere premuto il pulsante **1** / **2** / **3** / **4** per 3 secondi finché i numeri sul display non iniziano a lampeggiare, indicando che l'altezza corrente è stata salvata correttamente.



Blocco bambini

1. Blocco: Premere e tenere premuti contemporaneamente i pulsanti **1** e **2** per 3 secondi. Quando il display mostra "Loc", la scrivania è bloccata e non può essere regolata.

2. Sblocco: Premere e tenere premuti contemporaneamente i pulsanti **1** e **2** per 3 secondi. Quando il display cambia da "Loc" a mostrare l'altezza della scrivania, il blocco bambini viene rilasciato.



Ripristino

1. Tenere premuto **v** per abbassare il desktop alla sua posizione più bassa raggiungibile, quindi rilasciare.

2. Tenere premuto **v** per 5 secondi finché non appare "RST", quindi rilasciare.

3. Tenere premuto **v** di nuovo: il desktop si abbasserà ulteriormente e rimbalzerà, e verrà visualizzata l'altezza corrente. Rilasciare il pulsante per completare il reset.

Domande Frequenti (FAQ)

Sollevamento unilaterale della scrivania

Causa Possibile:

L'asta di sincronizzazione non è installata correttamente.

Soluzione:

Verificare se l'asta di sincronizzazione è completamente inserita nella colonna della gamba. In caso contrario, abbassare la scrivania nella sua posizione più bassa e reinstallare l'asta di sincronizzazione facendo riferimento all'adesivo di installazione della gamba o al manuale di istruzioni.

Se i passaggi precedenti non risolvono il problema, si prega di fare un video del problema e contattare l'assistenza post-vendita all'indirizzo support@yfs.life.

<p>Telecomando non funziona o non risponde</p>	<p>Cause Possibili:</p> <ol style="list-style-type: none"> 1. L'alimentazione non è collegata correttamente. 2. Il controller ha scarso contatto o non funziona correttamente. 3. Il fusibile è bruciato o il modulo di alimentazione è difettoso. <p>Soluzione:</p> <p>Scollegare tutti i collegamenti dei cavi e ricollegarli. Verificare se tutte le interfacce dei cavi sono collegate correttamente e saldamente. Assicurarsi che la spina di alimentazione sia inserita nella presa di corrente.</p> <p>Se i passaggi precedenti non risolvono il problema, si prega di fare un video del problema e contattare l'assistenza post-vendita all'indirizzo support@yfs.life.</p>
<p>Il tavolo risulta inclinato o sbilanciato</p>	<p>Possibili cause:</p> <ol style="list-style-type: none"> 1. Un'installazione errata che causa squilibrio. 2. Una delle gambe o dei piedini non è allineata correttamente. <p>Soluzione:</p> <ol style="list-style-type: none"> 1. Verificare i passaggi di installazione per assicurarsi che ogni gamba sia montata correttamente e che il tavolo sia livellato. 2. Regolare l'altezza dei piedini per riportare il desktop in posizione orizzontale. 3. Se il problema persiste, registrare un video del malfunzionamento e contattare l'assistenza clienti a support@yfs.life.
<p>Rumori insoliti o movimento irregolare durante l'alzata del tavolo</p>	<p>Possibili cause:</p> <ol style="list-style-type: none"> 1. Il carico sul desktop supera il limite consigliato (non oltre 100 kg). 2. Alcune connessioni del tavolo sono allentate, in particolare vicino alla barra di sincronizzazione. 3. Il motore potrebbe essere difettoso. <p>Soluzione:</p> <ol style="list-style-type: none"> 1. Verificare se gli oggetti sul desktop superano il limite di peso e ridurre il carico se necessario. 2. Controllare e stringere tutte le viti e i connettori per garantire la stabilità della struttura. 3. Se il problema persiste, registrare un video del malfunzionamento e contattare l'assistenza clienti a support@yfs.life.
<p>Il telecomando visualizza "RST", "E07" o "E08"</p>	<p>Causa Possibile:</p> <p>Scarso contatto del cavo del motore.</p> <p>Soluzione:</p> <p>Verificare che tutti i collegamenti dei cavi siano corretti e sicuri, quindi eseguire un ripristino. Se il problema persiste, si prega di fare un video del problema e contattare l'assistenza post-vendita all'indirizzo support@yfs.life.</p>
<p>Il telecomando visualizza "HOT"</p>	<p>Causa Possibile:</p> <p>La scrivania è entrata in modalità di protezione dal surriscaldamento.</p> <p>Soluzione:</p> <p>Attendere 20 minuti prima di utilizzare la scrivania. Se il problema persiste, si prega di fare un video del problema e contattare l'assistenza post-vendita all'indirizzo support@yfs.life.</p>

