

# INSTRUCTIONS DE MONTAGE

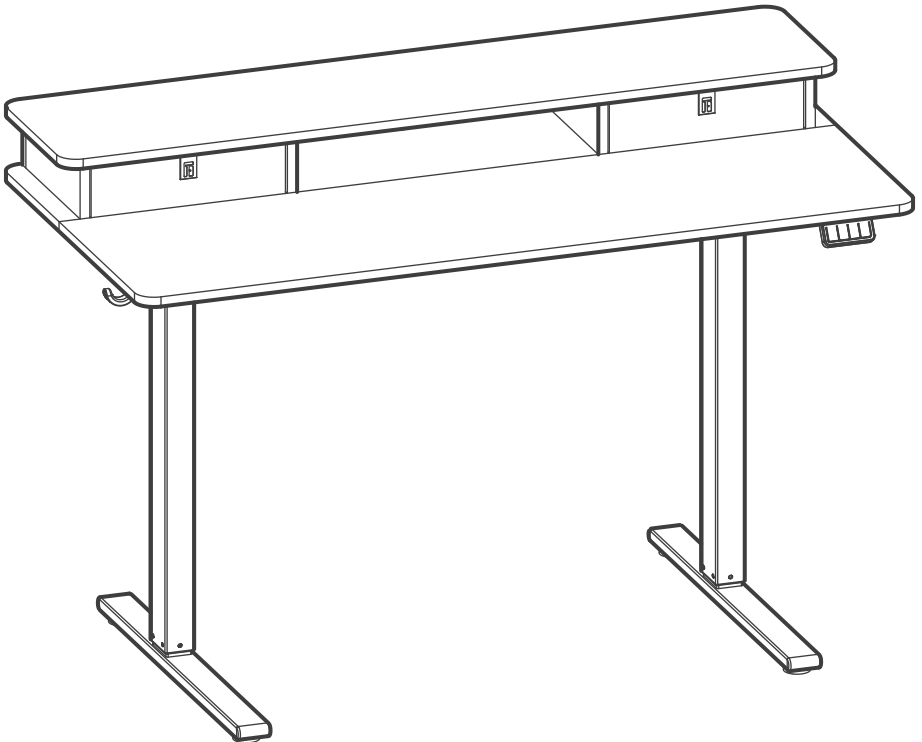

## English

### Caution

- Keep children and animals away from the desk during use. Ensure the desktop is not touching any walls.
- Remove obstacles taller than 20"/51cm from underneath the desk.
- Operate only in a working environment temperature of 32°F-104°F/0°C-40°C.
- Keep product away from corrosive gases, liquids and dusty objects.
- Keep hands, feet and other body parts in a safe position during operation. Anti-collision is not automatically enabled during all resets.
- The company does not bear any warranty or liability for damage and human injury caused by any abnormal or un-intended operation of the equipment.
- It is necessary to perform a manual reset after the initial installation or power cycling the equipment.

## Español

### Precaución

- Mantenga a los niños y animales alejados del escritorio durante su uso. Asegúrese de que el escritorio no toca ninguna pared.
- Retire aquellos obstáculos con una altura superior a 20"/51cm de debajo del escritorio.
- Opérela únicamente en una temperatura del entorno de trabajo de 32°F-104°F/0°C-40°C.
- Mantenga el producto alejado de gases corrosivos, líquidos y objetos con polvo.
- Mantenga las manos, pies y otras partes del cuerpo en una posición segura durante el funcionamiento. No se habilita la anticollisión de forma automática tras los reinicios.
- La empresa no ofrece ninguna garantía no asume ninguna responsabilidad por cualquier daño o lesión humana provocada por un funcionamiento anormal o no previsto del equipo.
- Es necesario realizar un reinicio manual tras la instalación inicial o el ciclo de encendido.

## Italiano

### Attenzione

- Tenere i bambini e gli animali lontani dalla scrivania durante l'uso. Assicurarsi che il piano non tocchi alcuna parete.
- Rimuovere gli ostacoli più alti di 20"/51cm da sotto la scrivania.
- Operare solo in un ambiente di lavoro con una temperatura di 32°F-104°F/0°C-40°C.
- Tenere il prodotto lontano da gas e liquidi corrosivi e oggetti polverosi.
- Tenere mani, piedi e altre parti del corpo in posizione di sicurezza durante il funzionamento. L'anti-collisione non è automaticamente attivata dopo il ripristino.
- La società non si assume alcuna garanzia o responsabilità per danni e lesioni umane causati da un funzionamento anormale o non previsto dell'apparecchiatura.
- È necessario eseguire un ripristino manuale dopo l'installazione iniziale o il ciclo di alimentazione.

## Deutsch

### Vorsicht

- Halten Sie Kinder und Tiere während der Benutzung vom Tisch fern. Achten Sie darauf, dass die Tischplatte keine Wände berührt.
- Entfernen Sie Hindernisse, die höher als 20"/51cm Zoll sind, von der Unterseite des Tisches.
- Betreiben Sie das Gerät nur in einer Arbeitsumgebung mit einer Temperatur von 32°F-104°F/0°C-40°C.
- Halten Sie das Produkt von ätzenden Gasen, Flüssigkeiten und staubigen Gegenständen fern.
- Halten Sie Hände, Füße und andere Körperteile während des Betriebs in einer sicheren Position. Der Antikollisionsschutz wird nach den Zurücksetzen nicht automatisch aktiviert.
- Das Unternehmen übernimmt keine Garantie oder Haftung für Schäden und Verletzungen, die durch einen abnormalen oder unbeabsichtigten Betrieb des Geräts verursacht werden.
- Nach der Erstinstallation oder dem Ersteinhalten der Stromversorgung muss eine manuelle Rückstellung vorgenommen werden.

## Français

### Attention

- Pendant l'utilisation, gardez les enfants et les animaux à l'écart du bureau. Veillez à ce que le bureau ne touche aucun mur.
- Éliminez les obstacles de plus de 20"/51cm pouces de hauteur sous le bureau.
- N'utilisez le produit que dans un environnement de travail dont la température est comprise entre 32°F-104°F/0°C-40°C.
- Éloignez le produit de toute source de gaz corrosifs, de liquides et d'objets poussièreux.
- Gardez les mains, les pieds et les autres parties du corps dans une position sûre lorsque vous utilisez l'appareil. L'anticollision n'est pas automatiquement activée après les réinitialisations.
- Aucune garantie ou responsabilité n'est assumée par la société pour les dommages et les blessures humaines causés par un fonctionnement anormal ou non intentionnel de l'équipement.
- Une réinitialisation manuelle est indispensable après l'installation initiale ou un cycle d'alimentation.

## 日本語

### 注意

- 本製品を使用している時、子供や動物から遠ざけてください。デスクトップが壁に触れていないことを確認してください。
- 机の底から20インチ/51cmより高い障害物を取り除いてください。
- 32°F-104°F/0°C-40°Cの作動環境温度のみで動作する。
- 本製品を腐食性ガス、液体、ほこりの多い物体から遠ざけてください。
- 操作中に手、足、その他の体の部分を安全な位置に保ってください。アンチ衝突は、すべてのリセット中に自動的に有効にされていません。
- 機器の異常または非意図的な操作によって引き起こされた損傷と人身傷害に対していかなる保証または責任も負いません。
- 初回装着または機器通電後、手動リセットが必要です。



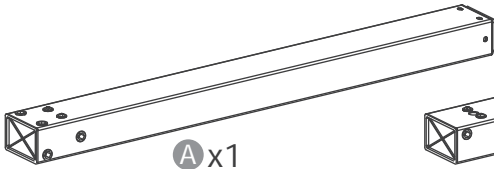

A x1

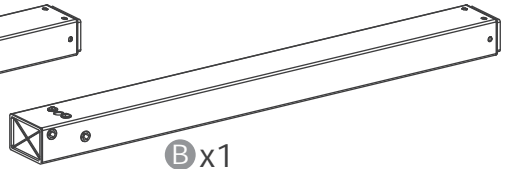

B x1

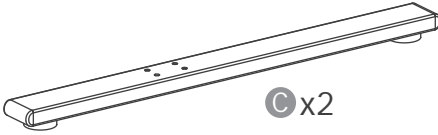

C x2

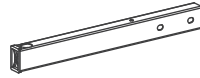

D x2



E x2

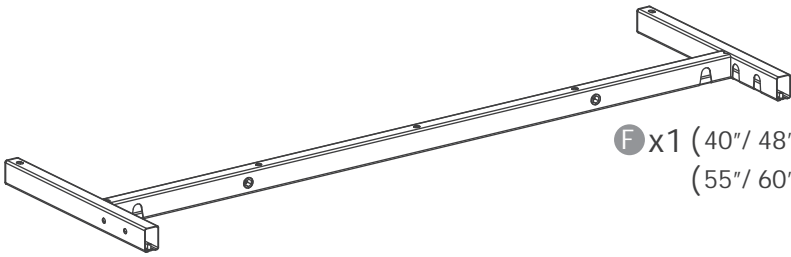

F x1 (40"/ 48": 935mm)  
(55"/ 60": 1335mm)

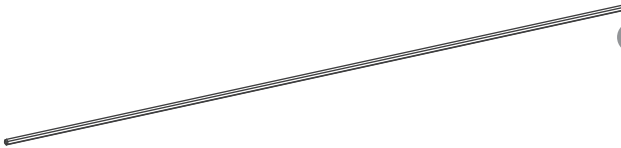

G x1 (40"/ 48": 885mm)  
(55"/ 60": 1285mm)

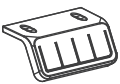

H x1



I x1

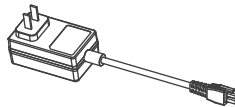

J x1

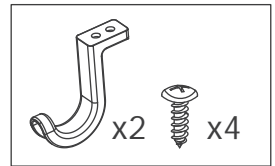

K

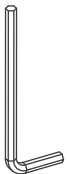

L x1



M x1

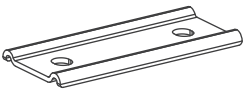
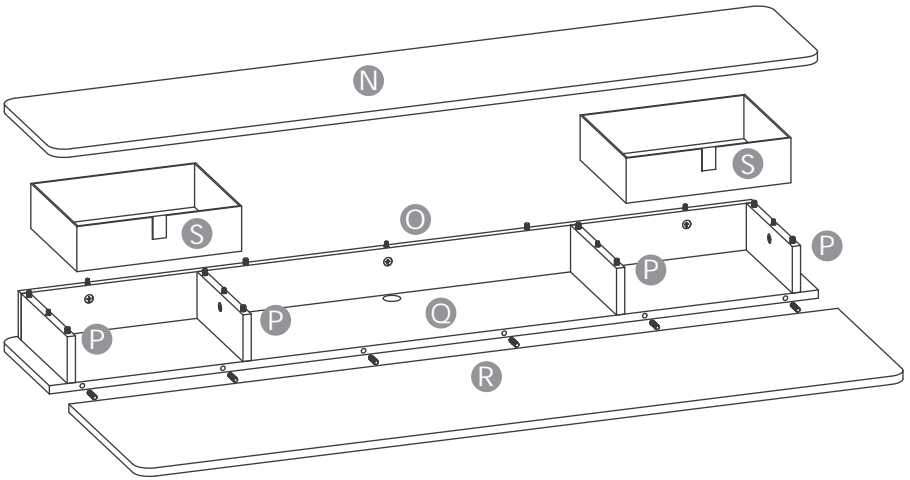

① x2 (40"  
100cm)  
x3 (48"  
120cm)  
x4 (55"/60"  
140cm/152cm)

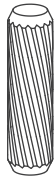

② x21 (40"  
100cm)  
x22 (48"/55"  
120cm/140cm)  
x23 (60"  
152cm)



③ x15 (40"  
100cm)  
x17 (48"  
120cm)  
x20 (55"/60"  
140cm/152cm)



④ x4

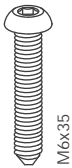

⑤ x14

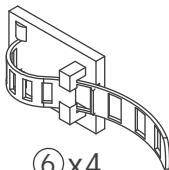

⑥ x4

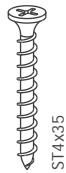

⑦ x11



⑧ x7



⑨ x7

## Pre-installation Guide

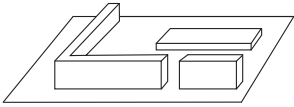

Assemble on a foam  
to prevent scratch

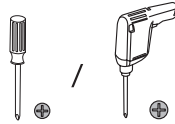

Phillips screwdriver or drill required  
(not provided)

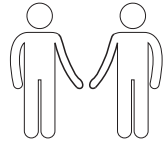

Get a friend for help

1

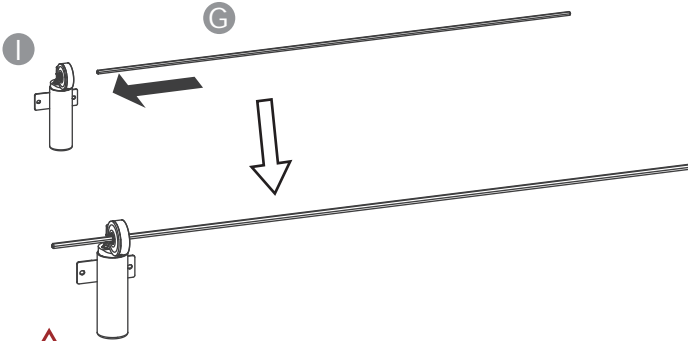

2



Utilisez une boîte pour aider lors de  
l'installation du cadre afin d'obtenir un  
équilibre pendant l'installation.

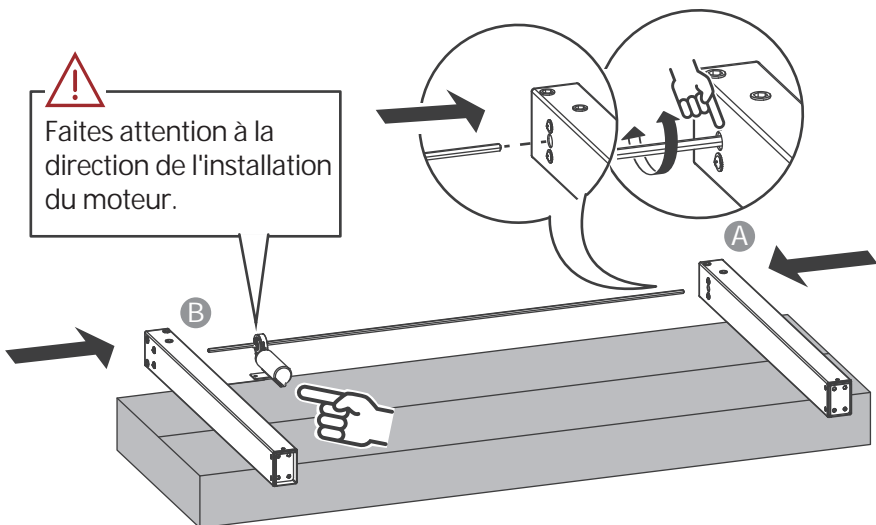

3

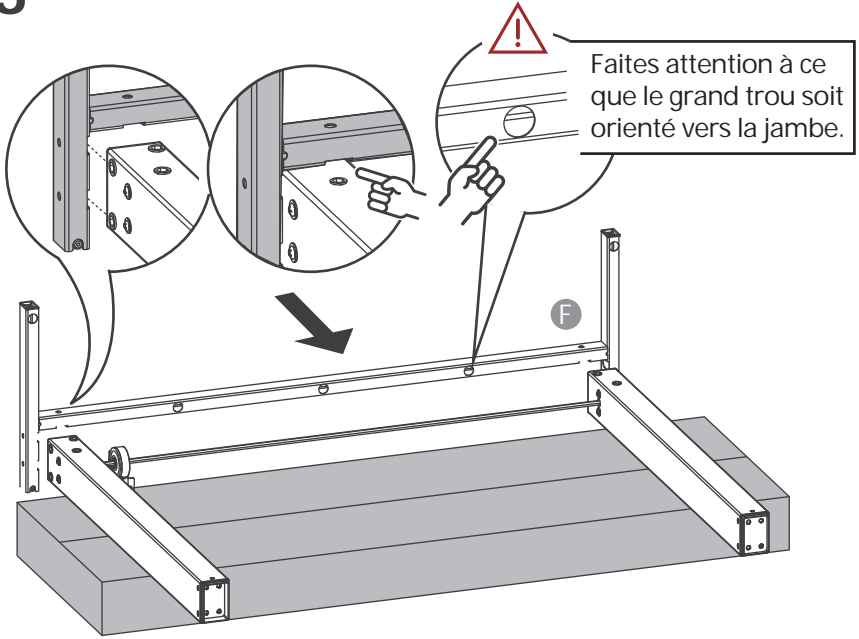

4

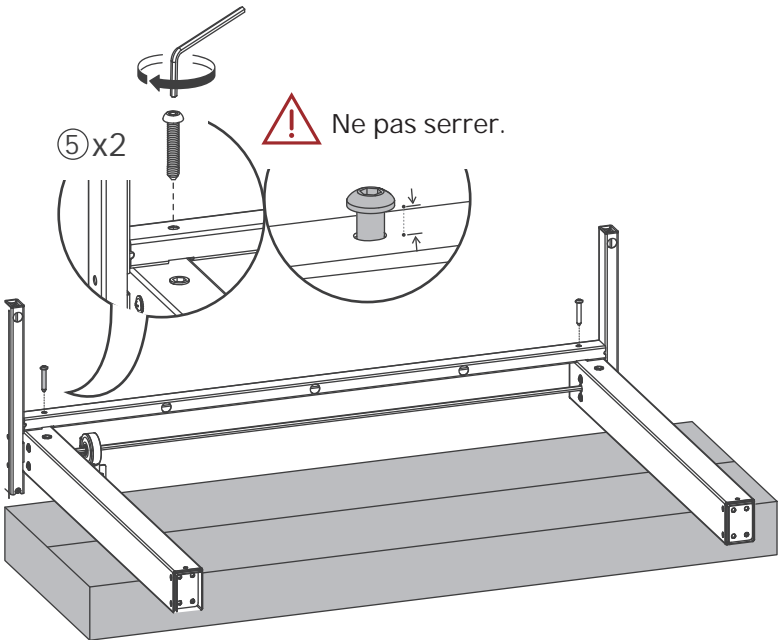

5

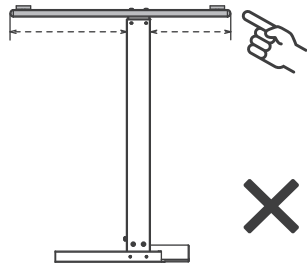
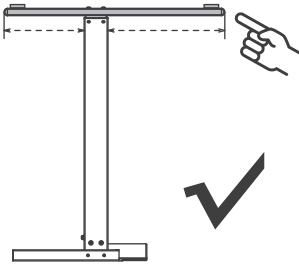
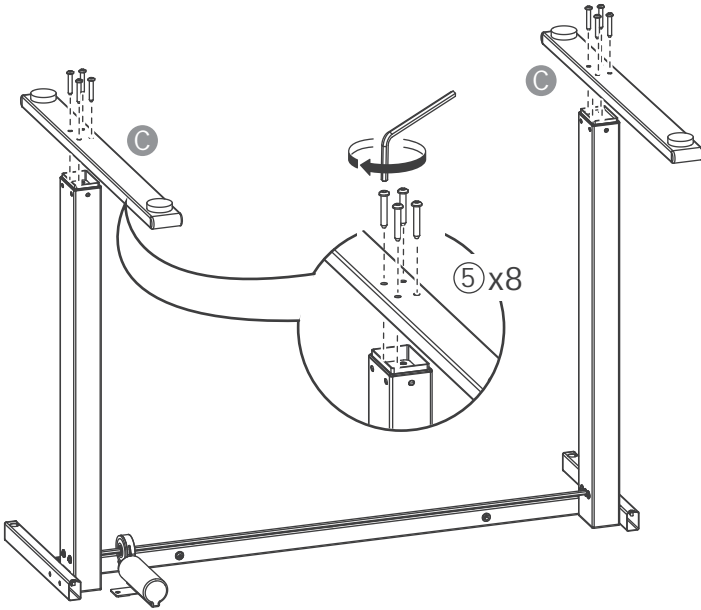

6

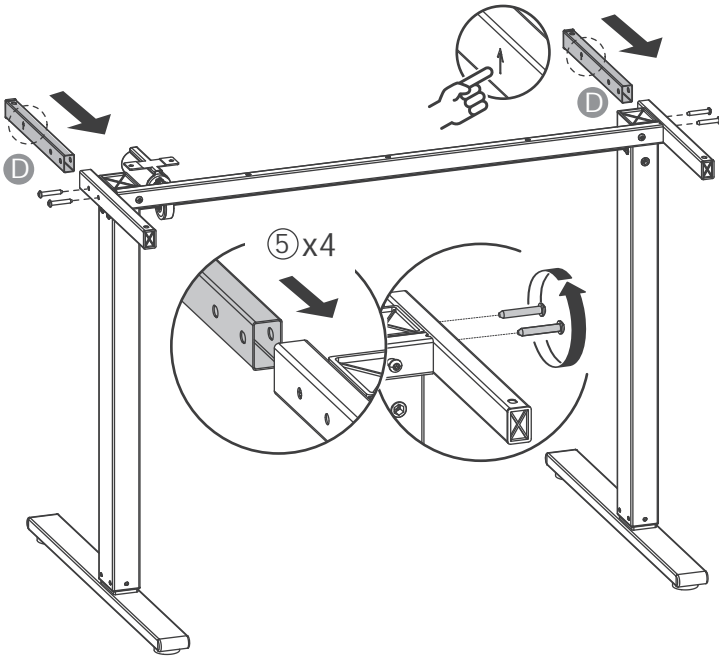

7

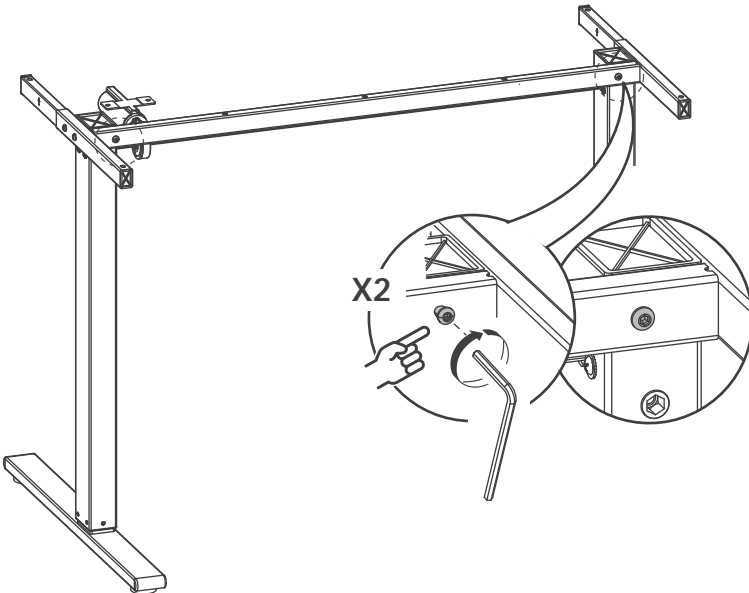



8

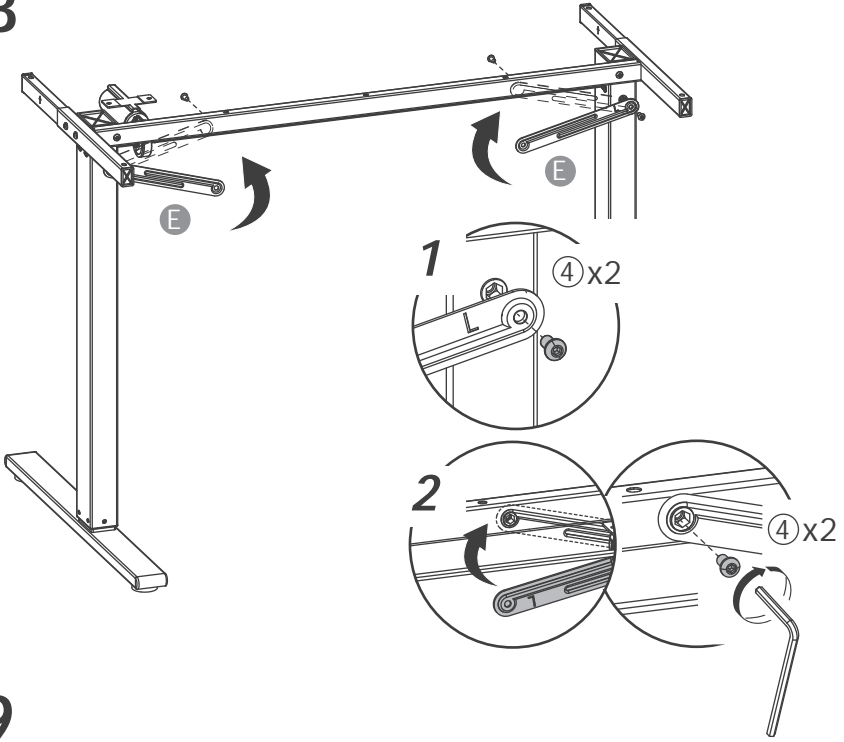

9

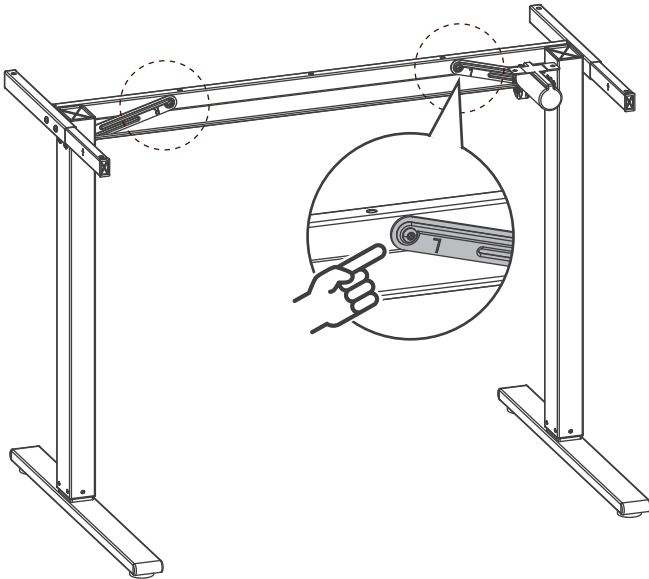

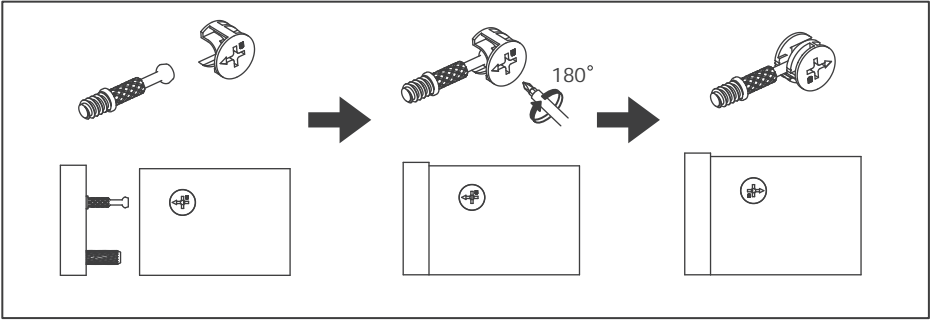

10

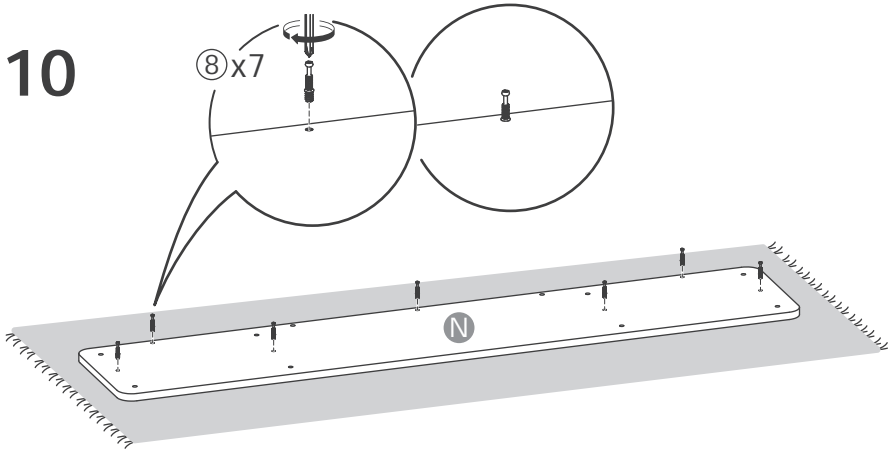

11

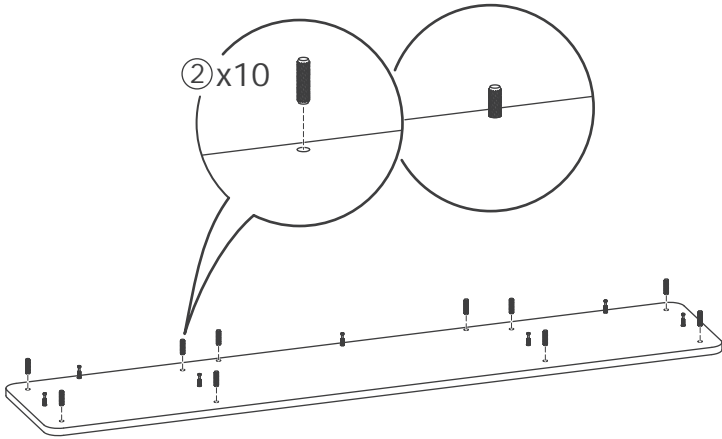

12

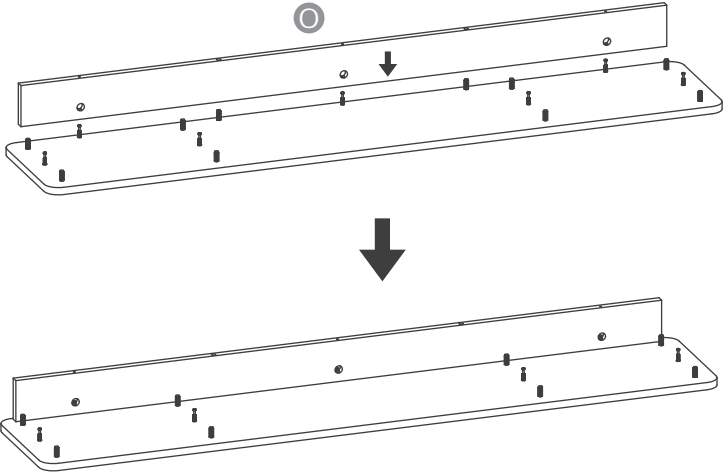

13

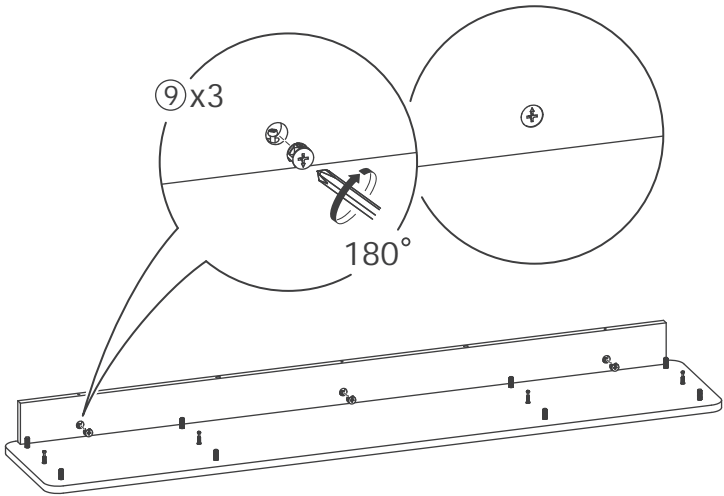

# 14

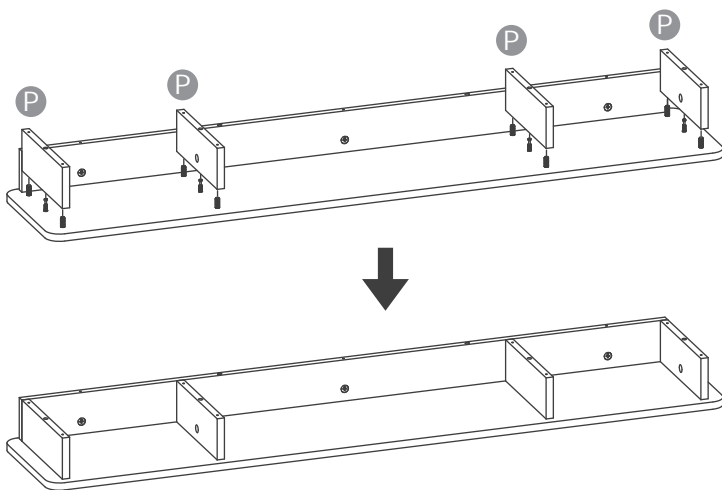

# 15

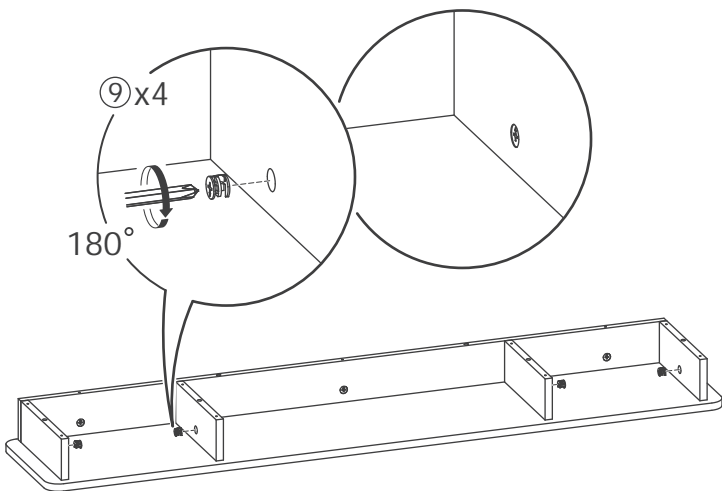

# 16

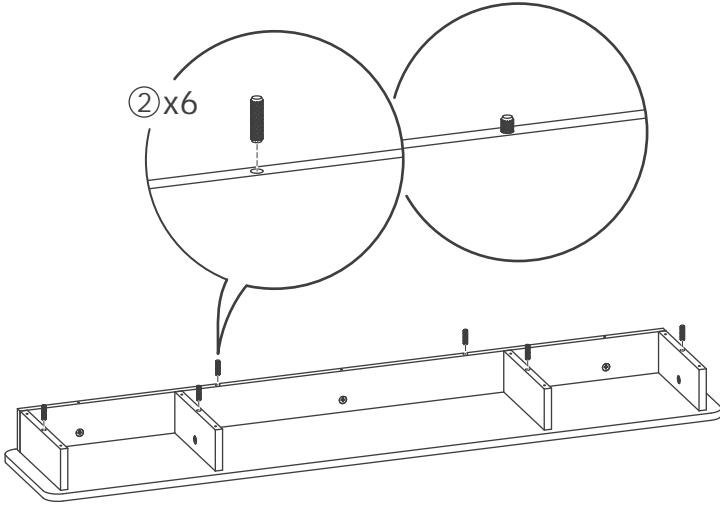

# 17

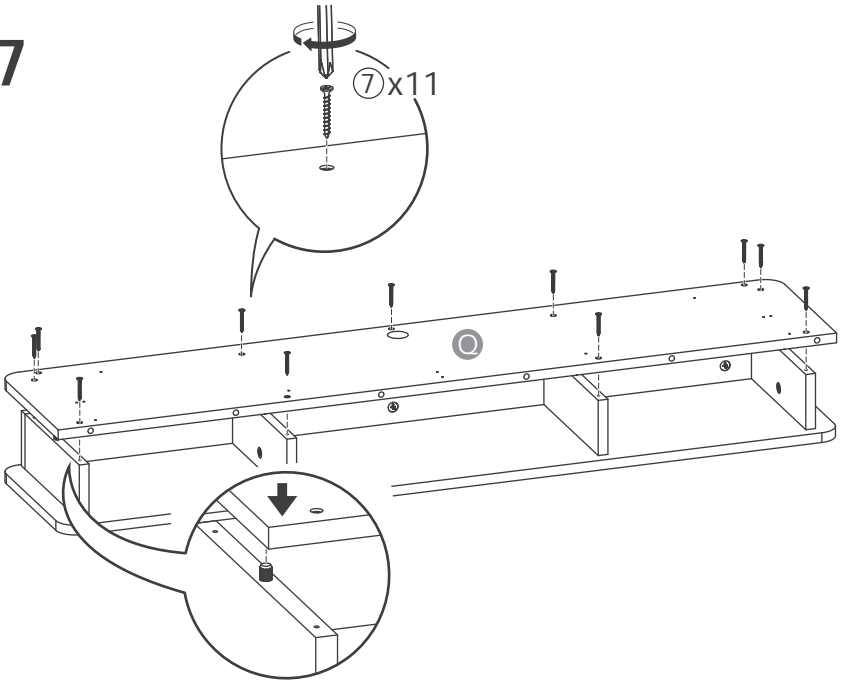

40"  
(100cm)

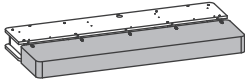

②x5

48"/55"  
(120cm/140cm)

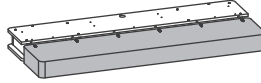

②x6

60"  
(152cm)

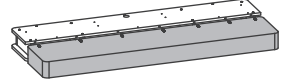

②x7

18 ②x6

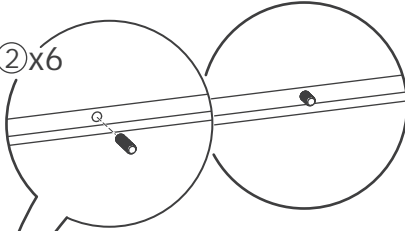

veuillez utiliser la boîte pour aider à maintenir l'équilibre pendant l'installation.

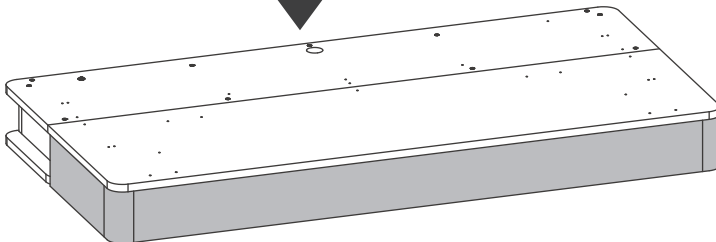
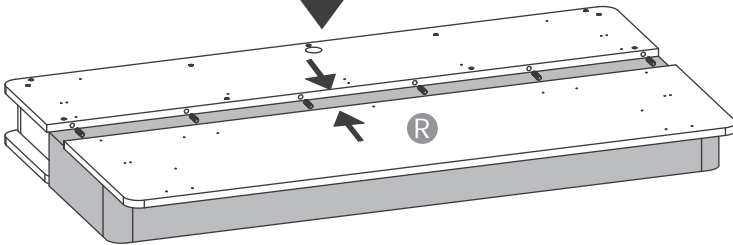
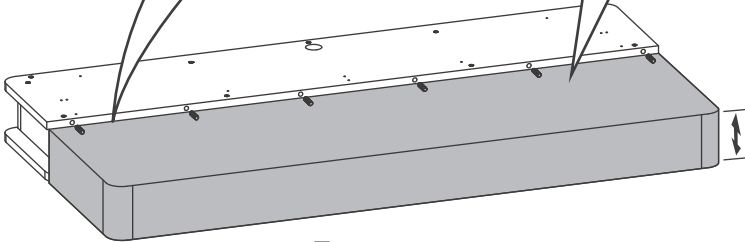

**40"**  
(100cm)

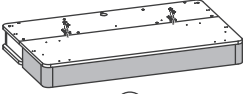

①x2  
③x4

**48"**  
(120cm)

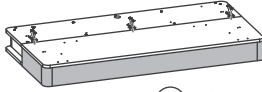

①x3  
③x6

**55" / 60"**  
(140cm/152cm)

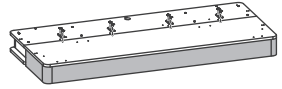

①x4  
③x8

**19**

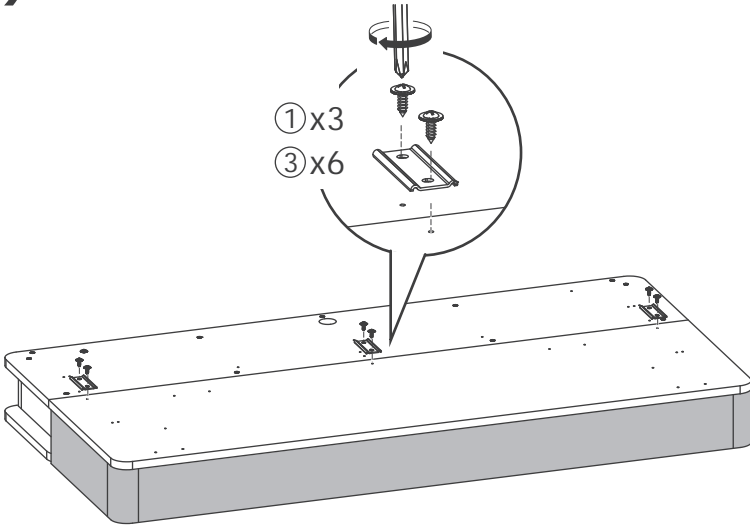

# 20

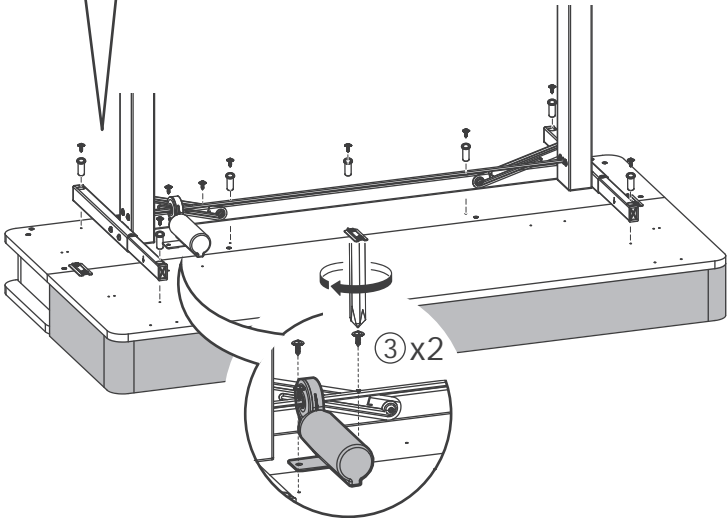
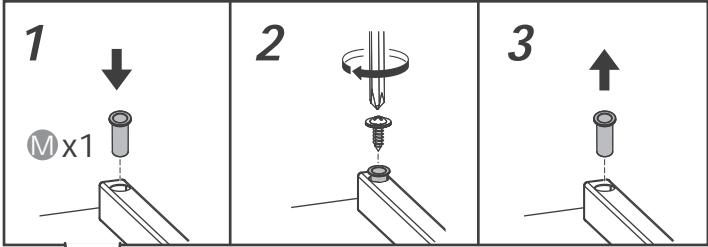
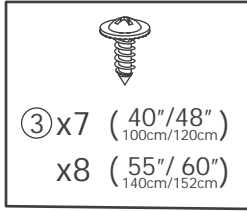



# 21

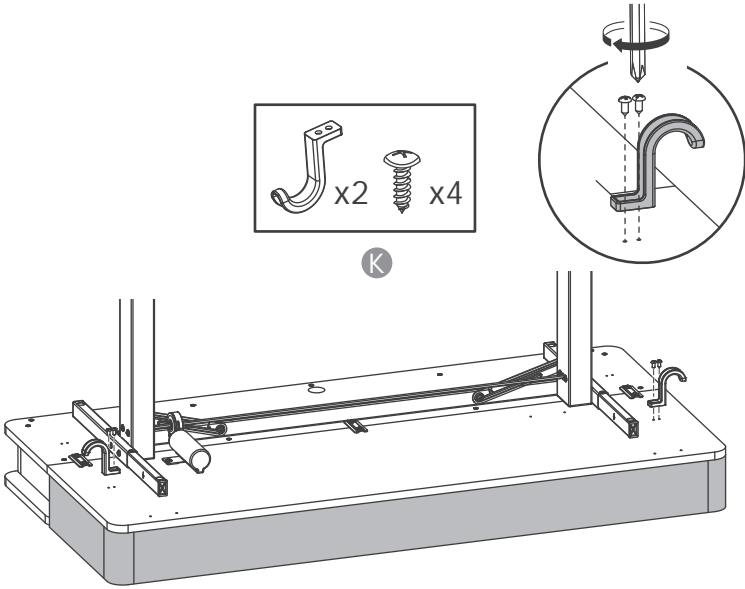

# 22

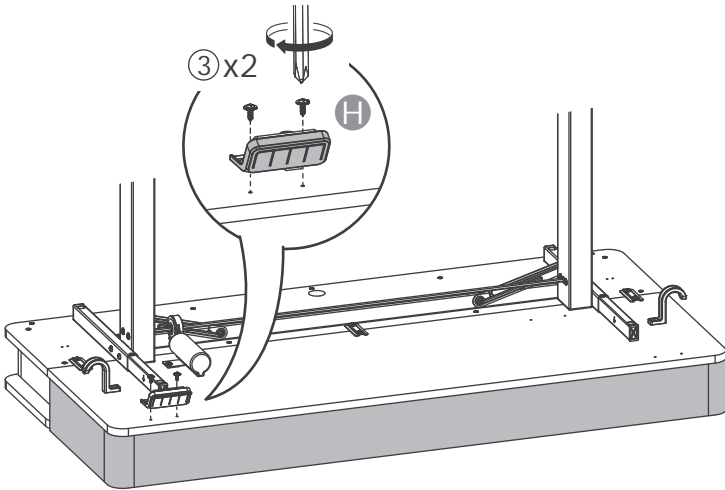

# 23

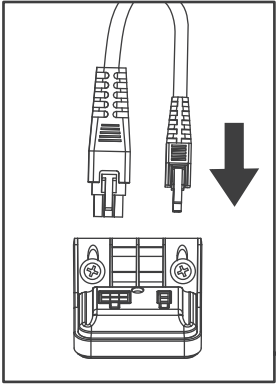
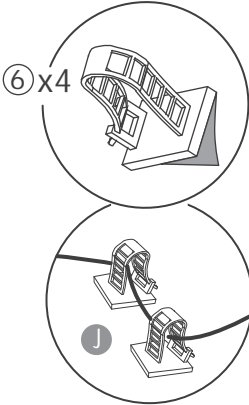
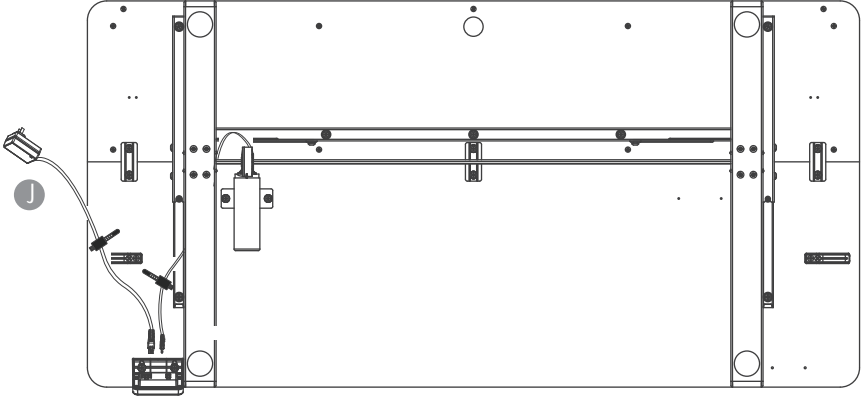

24

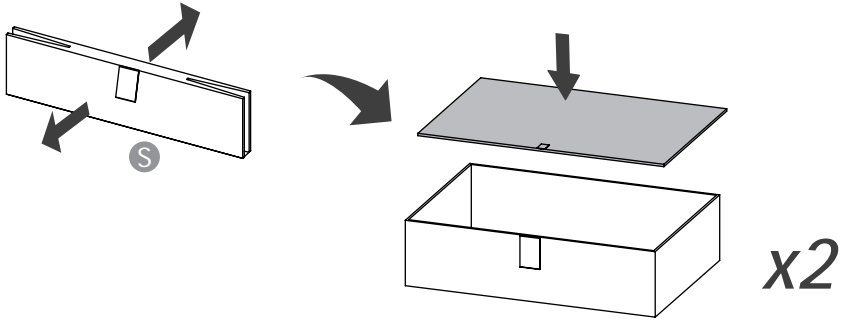

25

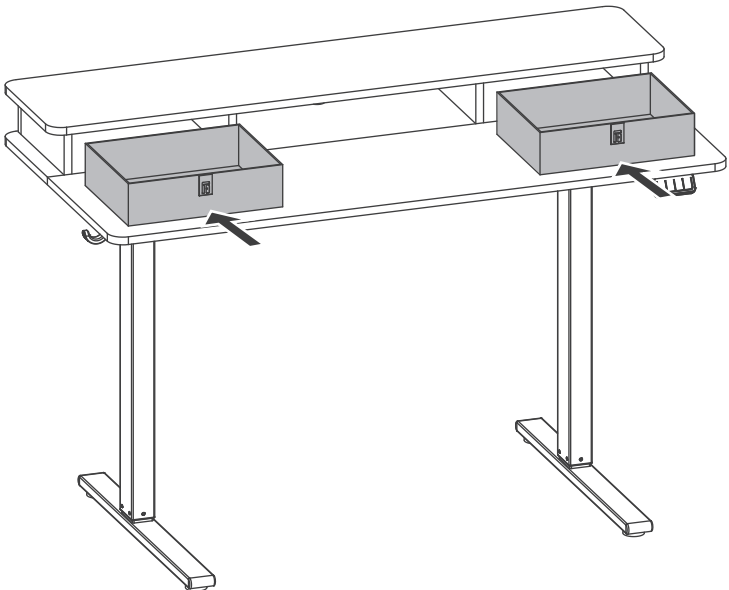

# 26

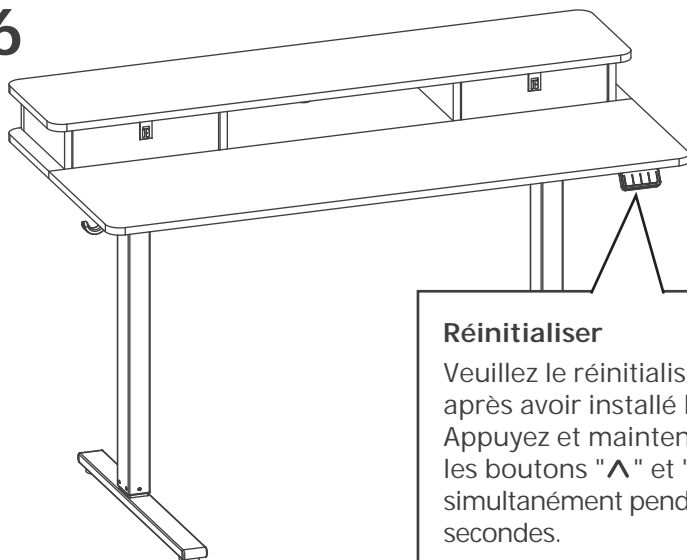

## Réinitialiser

Veillez le réinitialiser d'abord après avoir installé la table. Appuyez et maintenez enfoncés les boutons "∧" et "∨" simultanément pendant 5 secondes.

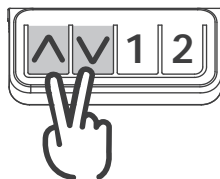

## Controller Instruction



English	20
---------	----

Deutsch	20
---------	----

Español	21
---------	----

Français	21
----------	----

Italiano	22
----------	----

日本語	22
-----	----

# English

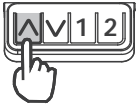

## Height Adjustment Function

Press and hold the "**^**" or "**v**" button to adjust the height.

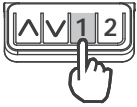

## Memory Key Function

Press the memory key "1" or "2", and the desk will automatically move to the preset height position.

Factory default: memory key "1" is set to the lowest height, and memory key "2" is set to the highest height.



## Height Setting Function

Press and hold the "**^**" or "**v**" button to adjust to the desired height, then press and hold the "1" or "2" key for 3 seconds to store the current height to the corresponding memory position.

## Reset Function

Press and hold the "**^**" and "**v**" button simultaneously for 5 seconds. The desk will automatically move down to the lowest point and stop, indicating a successful reset.

# Deutsch

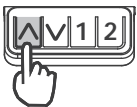

## Höhenverstellungsfunktion

Halten Sie die Taste "**^**" oder "**v**" gedrückt, um die Höhe einzustellen.

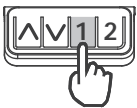

## Speichertastenfunktion

Drücken Sie kurz die Speichertaste "1" oder "2", und der Schreibtisch bewegt sich automatisch zur voreingestellten Höhe. Werkseinstellung: Die Speichertaste "1" ist auf die niedrigste Höhe eingestellt, und die Speichertaste "2" ist auf die höchste Höhe eingestellt.



## Höheneinstellungsfunktion

Halten Sie die Taste "**^**" oder "**v**" gedrückt, um die gewünschte Höhe einzustellen, und halten Sie dann die Taste "1" oder "2" 3 Sekunden lang gedrückt, um die aktuelle Höhe in der entsprechenden Speicherposition zu speichern.

## Reset-Funktion

Halten Sie gleichzeitig die Speichertasten "**^**" und "**v**" 5 Sekunden lang gedrückt. Der Schreibtisch bewegt sich automatisch nach unten bis zum tiefsten Punkt und stoppt, was auf eine erfolgreiche Rücksetzung hinweist.

## Español



### Función de Ajuste de Altura

Mantén presionado el botón "**^**" o "**v**" para ajustar la altura.



### Función de Tecla de Memoria

Presiona brevemente la tecla de memoria "1" o "2", y el escritorio se moverá automáticamente a la posición de altura preestablecida. Predeterminado de fábrica: la tecla de memoria "1" está configurada en la altura más baja y la tecla de memoria "2" está configurada en la altura más alta.



### Función de Configuración de Altura

Mantén presionado el botón "**^**" o "**v**" para ajustar a la altura deseada, luego mantén presionada la tecla "1" o "2" durante 3 segundos para almacenar la altura actual en la posición de memoria correspondiente.

### Función de Ajuste de Altura

Mantén presionadas simultáneamente las teclas de memoria "**^**" y "**v**" durante 5 segundos. El escritorio se moverá automáticamente hacia abajo hasta el punto más bajo y se detendrá, indicando un restablecimiento exitoso.

## Français



### Fonction de Réglage de la Hauteur

Appuyez et maintenez le bouton "**^**" ou "**v**" pour régler la hauteur.



### Fonction de la Touche Mémoire

Appuyez brièvement sur la touche mémoire "1" ou "2", et le bureau se déplacera automatiquement à la position de hauteur pré-réglée. Par défaut, la touche mémoire "1" est réglée à la hauteur la plus basse et la touche mémoire "2" est réglée à la hauteur la plus haute.



### Fonction de Réglage de la Hauteur

Appuyez et maintenez le bouton "**^**" ou "**v**" pour régler à la hauteur souhaitée, puis appuyez et maintenez la touche "1" ou "2" pendant 3 secondes pour enregistrer la hauteur actuelle à la position de mémoire correspondante.

### Fonction de Réinitialisation

Appuyez et maintenez simultanément les touches mémoire "**^**" et "**v**" pendant 5 secondes. Le bureau se déplacera automatiquement vers le bas jusqu'au point le plus bas et s'arrêtera, indiquant une réinitialisation réussie.

## Italiano

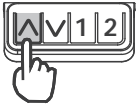

### Funzione di Regolazione dell'Altezza

Tenere premuto il pulsante "▲" o "▼" per regolare l'altezza.

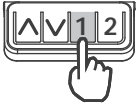

### Funzione del Tasto di Memoria

Premere brevemente il tasto di memoria "1" o "2", e la scrivania si muoverà automaticamente alla posizione di altezza preimpostata. Impostazione di fabbrica: il tasto di memoria "1" è impostato all'altezza più bassa, e il tasto di memoria "2" è impostato all'altezza più alta.



### Funzione di Impostazione dell'Altezza

Tenere premuto il pulsante "▲" o "▼" per regolare all'altezza desiderata, poi tenere premuto il tasto "1" o "2" per 3 secondi per memorizzare l'altezza corrente nella posizione di memoria corrispondente.

### Funzione di Reset

Tenere premuti contemporaneamente i tasti di memoria "▲" e "▼" per 5 secondi. La scrivania si muoverà automaticamente verso il basso fino al punto più basso e si fermerà, indicando un reset avvenuto con successo.

## 日本語

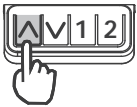

### 高さ調節機能

"▲"または"▼"ボタンを押し続けて高さを調節します。

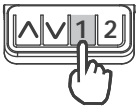

### メモリボタンの機能

メモリボタンの"1"または"2"を押すと、デスクは自動的に設定された高さの位置に移動します。初期設定：メモリボタン"1"は最低位置に、メモリボタン"2"は最高位置に設定されています。



### 高さ設定機能

"▲"または"▼"ボタンを押し続けて希望の高さに調整し、"1"または"2"ボタンを3秒間長押しして、現在の高さを対応するメモリ位置に保存します。

### リセット機能

"▲"と"▼"のメモリボタンを同時に5秒間押し続けます。デスクは自動的に最低位置まで下がり、停止してからリセットが完成します。



FR  
Cet appareil  
se recycle

REPRISE  
À LA LIVRAISON



À DÉPOSER  
EN MAGASIN



À DÉPOSER  
EN DÉCHÈTERIE



Points de collecte sur [www.quefairedemesdechets.fr](http://www.quefairedemesdechets.fr)  
Privilégiez la réparation ou le don de votre appareil !